



Eventing IRELAND



RULE BOOK 2026

Lucy Ferris – 2026 Youth Ambassador

Cover photo credit: Tony Walker Photography www.tonywalkerphotography.com

NutriScience

www.NutriScience.ie



 www.nutriscience.ie

 +353 (0)51 30 40 10

 info@swedencareireland.com

 +353 (0)85 862 15 13

Contents

1	GENERAL RULES	2
1.1	The Structure Of Eventing Ireland	2
1.2	Aims	2
1.3	Acceptance of the Rules	2
1.4	Data Protection/GDPR	3
1.5	Affiliation	3
1.6	Unaffiliated Events	4
1.7	Volunteering	4
1.8	Conflict of Interest	4
1.9	Insurance	4
1.10	Photographers and Traders	5
1.11	Litter and Respect of Property	5
1.12	Stables	6
1.13	Dogs	6
1.14	Bikes, Scooters and Buggies/Pushchairs	6
2	MEMBERSHIP AND REGISTRATION	7
2.1	Membership	7
2.2	Horse Registration	8
2.3	Day Membership and Day Registration	8
2.4	Day Memberships and Registrations for EI105, EI100, EI90 and EI80 Classes	9
2.5	Day Memberships For EI110 Classes	9
2.6	Horse Day Registrations for EI110 Classes	9
3	HORSE TRIALS/EVENTS	10
3.1	One Day Events	10
3.2	Three Day Events	10
3.3	Event Details	10
3.4	Event Programmes	10
3.5	Health and Safety	11
3.6	Disclaimer of Liability	11
3.7	Reservation of Rights	11
3.8	Entries/Substitutions of Horse and/or Athlete	11
3.9	Event Cancellation	12
3.10	Refund of Entry Fee after an Event Cancellation	12
3.11	Transfer of Venue/Entries to another Venue	12
3.12	Declarations	13
3.13	Withdrawals and Refunds	13
3.14	Amalgamation of Classes	13
3.15	Start Fees	13
3.16	Order of Phases	13
3.17	Relative Influence	14
3.18	Classification	14
3.19	Allocation of Entries from Waitlist	14
3.20	Appearance Money	14
3.21	Hors Concours (HC)	14
3.22	Order of Starting	14
3.23	Athlete Numbers	15
3.24	Orders from Officials	15
	EVENT CLASSES AND GENERAL GUIDANCE.....	18
4	PARTICIPATION OF ATHLETES AND HORSES.....	18
5	DEFINITION OF ATHLETE MEMBERSHIP TYPES.....	18
5.1	Senior Athletes	18
5.2	Restricted Athletes	18
5.3	Amateur Athletes	18
5.4	Young Rider Athletes	19
5.5	Junior Athletes	19
5.6	Pony Athletes	19

5.7	Definition of Pony Classes	20
5.8	Upgrading – Pony Classes	20
5.9	Definition of Approved Eventing Coaches	20
5.10	Underage Grading Categories	20
6	CLASSES AND GENERAL GUIDANCE	21
6.1	ERQI Information	21
6.2	Class Types and Qualifying Criteria	21
6.3	Entry Fees	27
7	PRIZES	27
7.1	Prize Money	28
7.2	Prize Givings	29
8	POINTS AWARDED	29
8.1	International Points and MERs Gained Overseas	30
9	OFFICIALS AND JUDGES	31
9.1	Eventing Ireland Technical Advisor, Steward and Assistant Steward	31
9.2	Safety Steward	31
9.3	Dressage Judges	32
9.4	Show Jumping Judges	32
9.5	Cross Country Course Designer	32
9.6	Cross Country Controller	33
9.7	Cross Country Fence Judges	33
10	ATHLETE INFORMATION	34
10.1	Number of Horses ridden by an Athlete	34
10.2	Dangerous Riding	35
10.3	Elimination Before Cross Country	35
10.4	Athlete Downgrading	35
10.5	After Elimination or Retiring	36
10.6	Technical Elimination	36
10.7	Riding-in Competition Areas and Schooling	36
10.8	Ride In / Warm Up	36
10.9	Lungeing	37
11	ATHLETE DRESS	38
11.1	Athlete Dress Code during Competition	38
11.2	Protective Headgear	39
11.3	Hair and Jewellery	40
11.4	Mounted Head Cameras	40
11.5	Body Protectors	40
11.6	Inflatable / Air Jackets	40
11.7	Riding Boots / Gaiters	40
11.8	Whips	40
11.9	Spurs	41
11.10	Earphones	41
11.11	Mobile Phones	41
12	SADDLERY AND EQUIPMENT	41
12.1	Inspection of saddlery	41
12.2	Saddlery for Phases	41
13	WEARING OF IRISH TRICOLOUR	43
13.1	Irish Tricolour Badges	43
13.2	Irish Tricolour on Saddlecloths	43
14	SPONSORSHIP & ADVERTISING	44
14.1	Sponsorship of Individuals	44
14.2	Advertising and Logos: Athletes	44
14.3	Advertising and Logos: Horses	44
15	HORSE INFORMATION	44
15.1	Ponies	45
15.2	Upgrading of Horses	45
15.3	Downgrading of Horses	45
16	VETERINARY AND HORSE WELFARE	45
16.1	Destruction of severely injured horses	46



16.2	Prohibited Substances - Horses	46
16.3	Lameness - Dressage	46
16.4	Blood on Horses	46
16.5	Unfitness of horses	47
16.6	Horse Fall	47
16.7	Rapping	47
16.8	Abuse of Horse	47
16.9	Use of Whip	48
16.10	Warnings and Penalties	48
16.11	Participation of Horses	48
16.12	Unattended Horses	49
16.13	The FEI Code of Conduct for the Welfare of the Horse	49
17	PASSPORTS AND VACCINATIONS	51
17.1	Passports	51
17.2	Vaccinations : National Competitions	51
18	MEDICAL	53
18.1	Athlete Medical Information	54
18.2	Athlete Fall – Definition and Procedure	54
18.3	Concussion	55
18.4	Medical Fitness	55
18.5	Prohibited Substances - Athletes	55
19	SCORING (One Day Events).....	57
19.1	Scoring – Dressage (National Tests)	57
19.2	Scoring – Dressage (FEI Tests)	57
19.3	Scoring – Show Jumping	57
19.4	Scoring – Cross Country	57
19.5	Equality of Marks	58
19.6	Publication of Results	58
20	OBJECTIONS AND DISCIPLINARY PROCEDURES	58
20.1	Objections	58
20.2	Breach of FEI / HSI / IOC Rules	59
20.3	Reprimand/Disgraceful Conduct	59
20.4	Fines	59
20.5	Yellow Warning Cards and Verbal Reprimands	59
20.6	Eventing Steward – Disciplinary Powers	60
20.7	Eventing Ireland Disciplinary Committee	61
20.8	Hearing Procedures	61
20.9	Determination	62
20.10	Penalties	63
20.11	Appeals	63
20.12	Rules on Social Media	63
	ONE DAY EVENTS : GENERAL GUIDANCE	65
21	DRESSAGE	65
21.1	Sound of bell	65
21.2	Salute	65
21.3	Error of course	65
21.4	Error of test/execution	65
21.5	Unnoticed error	65
21.6	Dressage Penalties	65
21.7	Reasons for Elimination	66
21.8	Permitted Dressage Tests	67
21.9	Dressage Arena Layout	68
22	SHOW JUMPING GENERAL	69
22.1	Show Jumping Course	69
22.2	Show Jumping Obstacles	69
22.3	Cups/Safety Cups	69
22.4	Course and Obstacles	69
22.5	Heights, distances and speeds	71
22.6	Jumping Combinations:	71

22.7	Show Jumping Penalties	71
22.8	Elimination	72
22.9	Statutory Elimination	72
22.10	Technical Elimination	72
22.11	Practice Obstacles	73
23	CROSS COUNTRY	75
23.1	Prior Knowledge	75
23.2	Access to the Cross Country Course	75
23.3	Plan of XC Course	75
23.4	Method of Starting	75
23.5	Time Keeping	75
23.6	Errors of Course	76
23.7	Pacing and Dismounting	76
23.8	Overtaking	76
23.9	Athletes in Difficulty	76
23.10	Stopping Athletes	76
23.11	Unauthorised Assistance	77
23.12	Exceptions	77
23.13	Emergency Flags	77
23.14	Marking of the XC Course	77
23.15	Safety Flags	77
23.16	Class Indicator Flags	78
23.17	Fences with Frangible/Breakable Devices	78
23.18	Modification of the Course	79
23.19	Distances, Speed and Jumping Efforts	79
23.20	Cross Country Obstacles	80
23.21	Cross Country Intervals	81
23.22	Measurement of Cross Country Obstacles	81
23.23	Type of Obstacles	81
23.24	Permitted Dimensions of Obstacles	82
23.25	Cross Country Errors and Penalties	83
23.26	Definition of Cross Country Penalties	83
	INTERNATIONAL EVENTS	86
24	GENERAL GUIDANCE	86
25	SELECTION FOR HSI HIGH PERFORMANCE SQUADS	86
25.1	Senior Athlete Selection	86
25.2	Young Rider Athlete Selection	86
25.3	Junior Athlete Selection	87
25.4	Pony Athlete Selection:	87
26	PROCEDURE FOR INTERNATIONAL APPLICATIONS	87
26.1	New HSI FEI process effective from 2026	88
26.2	Senior Athlete Participation at International Events	89
26.3	Young Rider Athlete Participation at International Events	89
26.4	Junior Participation at International Events	89
26.5	Pony Athlete Participation at International Events	89
27	CONDITIONS	89
28	ATHLETE INFORMATION	90
28.1	Participation Restrictions (Article 504)	90
28.2	FEI Technical Requirements For Participation	91
28.3	Nationality of Athlete & Owner	95
28.4	Overseas International Entries	95
28.5	Nationality Status of Athletes	95
29	HORSE INFORMATION	96
29.1	Participation of Horses	96
29.2	Participation of Ponies	96
29.3	Vaccinations and Infectious Diseases at FEI Events	97
30	EVENTING IRELAND MERs.....	100
30.1	Eventing Ireland MERs for Horses and Athletes	101
30.2	Eventing Ireland MERs for Ponies and Pony Athletes	105



APPENDIX A: Plan of 20m x 40m Dressage Arena	106
APPENDIX B: Plan of 20m x 60m Dressage Arena	107
APPENDIX C & D: Guidelines on Use of Tack.....	108
30.2 Action of Bits	108
30.3 Material:	109
30.4 Permitted Snaffles (see diagrams)	109
30.5 Illegal Bits	109
30.6 Snaffles - Permitted Mouthpieces	110
30.7 Permitted Cheek pieces:	111
APPENDIX E: Permitted Reins for Lungeing and Permitted Nosebands	114
APPENDIX F: Cross Country Obstacles	117
APPENDIX G: Measuring Cross Country Obstacles	118
APPENDIX H: Diagrams of Cross Country Obstacles and Faults	119
APPENDIX I: Examples of Practice Show Jumping Fences not Allowed	123
APPENDIX J: Prohibited Substances – Horses.....	124
APPENDIX K : Prohibited Substances - Athletes.....	125
APPENDIX L: Code of Ethics & Good Practice for Children’s Sport in Ireland	126
APPENDIX M : Approved Hat Safety Standards.....	127
APPENDIX N: Eventing Ireland Stewards 2026	129
APPENDIX O: Eventing Ireland Accredited Course Designers 2026	130
APPENDIX P: Training Classes: Arena Eventing & Combined Training Rules	131
APPENDIX Q: Medical Cover at Events	134
APPENDIX R: Dates Committee - DC	135
APPENDIX S: Important Contact Information	140
APPENDIX T: FEI Code of Ethics	140

LIST OF AMENDMENTS TO EVENTING IRELAND RULE BOOK 2026		
DATE	RULE NO	CHANGE
14 April 2026	30 & 30.2	Change in CCI1* Intro and CCIP2 MERs

**EVENTING IRELAND RULE BOOK**

Effective 1 January 2026

All Rule Changes from the previous year are marked in RED

Eventing Ireland is the national governing body responsible for the sport of Eventing in Ireland.

The Eventing Ireland registered office is:

Eventing Ireland
1st Floor Beech House
Millennium Park
Osberstown
Naas
Co Kildare W91 TK7N

Telephone: +353 (0)83 020 0414 (Alison)
Or +353 (0)83 026 0501 (Tricia)

Website: www.eventingireland.com

Head Office Hours are 9am – 1pm and 2pm - 5pm Monday to Friday
Phone Lines are open between 9am-1pm only

Head Office is closed Saturday and Sunday and Bank Holidays

Please note, Head Office staff work remotely

All enquiries regarding Rules should be addressed in the first instance to
alison@eventingireland.com

1 GENERAL RULES

1.1 The Structure Of Eventing Ireland

The Society is divided into five semi-autonomous regions, Northern, North Leinster, South Leinster, Western and Munster, each with its own Regional Committee. The Regional Committees are responsible for the development of the sport of Eventing, and for all the National Events that take place under the auspices of Eventing Ireland in their respective regions.

The five regions are divided as follows:

Northern	Antrim, Armagh, Londonderry/Derry, Down, Fermanagh, Tyrone
North Leinster	Cavan, Dublin (North of the Liffey), Longford, Louth, Meath, Monaghan, Westmeath
South Leinster	Carlow, Dublin (South of the Liffey), Kildare, Kilkenny, Laois, Offaly, Wexford, Wicklow
Munster	Cork, Kerry, Limerick, Tipperary, Waterford
Western	Clare, Donegal, Galway, Leitrim, Mayo, Roscommon, Sligo

The Society publishes all the Event Schedules on its website which includes the relevant details of the approved events for the forthcoming season. It also lists the principal Officers, Regional Co-Ordinators and contact numbers for the Regional Committees.

The attached rules are known as “THE RULES for EVENTING IRELAND” have been approved and adopted by The Society. These rules will apply to all Events run under the auspices of Eventing Ireland, from here on.

1.2 Aims

Eventing constitutes the most complete combined equestrian Competition, demanding of the Athlete considerable experience in all branches of equitation and a precise knowledge of their Horse’s ability, and of the Horse a degree of general competence, resulting from intelligent and progressive training.

The Cross Country Test constitutes the most exciting and challenging all-round test of riding ability and horsemanship where correct principles of training and riding are rewarded. This test focuses on the ability of Athletes and Horses to adapt to different and variable conditions of the Competition (weather, terrain, obstacles, footing, etc) showing jumping skills, harmony, mutual confidence, and in general “good pictures”.

This test requires by all involved special awareness and acceptance of a certain level of risk inherent to the particular challenging and exciting nature of the test.

Every effort must be made to ensure that, at each level, responsible Athletes are participating with progressively trained Horses in order not to be exposed to a higher risk than which is strictly inherent to the nature and level of the Competition.

Eventing Ireland wishes to encourage these aims and to bring more owners and Athletes into the sport of Eventing.

1.3 Acceptance of the Rules

Membership of Eventing Ireland is conditional upon the acceptance of these rules. It is the personal obligation of all Members, Officials and Organisers to familiarise themselves, and be conversant, with the Rules and Regulations. The appointment of any official does not absolve any member from such obligation. Eventing Ireland reserves the right, without giving a reason, to refuse membership or to refuse to renew the membership of any Eventing Ireland member. Making an entry for any official Event (One or Three Day) constitutes acceptance of these Rules and binds an entrant to abide by them.

All members are responsible for knowing and complying with these Rules.

Rule changes will be published in any schedule and on the Eventing Ireland Website, under Rules in the Downloads Section. Failure to comply with any rule change so published will be considered a breach of these Rules.

These rules are used in conjunction with the FEI Rules for Eventing, Dressage and Jumping and FEI Event Code of Conduct, please refer to Appendix T

Not every eventuality can be provided for in these rules. In any unforeseen or exceptional circumstances it is the duty of the relevant officials to make a decision in a sporting spirit and to approach as nearly as possible the intention of these rules.

1.4 Data Protection/GDPR

Any information provided in connection with membership applications will be used to process membership and may be disclosed to Event Organisers for the running of events. In the case of Home International events, this data may be disclosed to third party organisations in order to provide online results. Please refer to the Eventing Ireland GDPR and Privacy Policy Statement <https://www.eventingireland.com/app/uploads/2026/01/GDPR-Policy.pdf>

Athlete results will be displayed on the EI website and may be displayed on the Event Organiser's website, and any site owned by the provider of an online results system.

Athlete's images may also be used for publicity purposes on EI's website or social media pages. (See Rule 1.10 Photographers and Traders).

All members and day members must read and agree to the storage and use of their data in accordance with Eventing Ireland Privacy Policy (which is published on the Eventing Ireland website). A Data Protection Consent Form must be completed and sent to Head Office for processing.

Should a Member receive an injury as the direct result of an accident occurring whilst participating in any Event organised by EI or its Affiliated Event Organisers, medical reports relating to the member's condition will be passed to EI Head Office. Medical Reports passed to EI will be held on record.

1.5 Affiliation

Anyone wishing to organise a National One Day Event or an approved training event should firstly contact Eventing Ireland Head Office, who is then at liberty to delegate authority to any person, or group, to further the process.

International Events and National Championships take precedence over One Day Events, which must be approved by Eventing Ireland.

National Date applications for the following year are approved in principle by the National Dates Committee and have final approval by the Eventing Ireland Board. An application by a venue for a date does not mean it will be accepted by the National Dates Committee or Eventing Ireland Board. The National Dates Committee and Eventing Ireland Board has the right to refuse or retract a date or class on the calendar at any time.

The date agreed upon and published on the website may not be altered without the permission of Eventing Ireland.

All Events consist of three separate tests: Dressage, Show Jumping and Cross Country, the penalty marks being cumulative. Eventing Ireland official Events are those held under the following rules and are either event financed by and organised on behalf of Eventing Ireland or Affiliated Events financed and organised by an independent individual or body affiliated to Eventing Ireland.

Please refer to Appendix P : *Training Classes: Arena Eventing & Combined Training Rules* or Appendix R: *Dates Committee* for full rules on applying for National or Training Dates.

1.6 Unaffiliated Events

An affiliated event may not run any unaffiliated events within an 80 mile radius of other EI events or in the same region so as to minimise the loss of entries to an Eventing Ireland affiliated event on the calendar.

Event organisers may run events under the rules of The Irish and British Pony Clubs and Riding Clubs, or any other affiliate of Horse Sport Ireland (HSI) and FEI events.

A venue which has signed the Event Agreement and runs an unaffiliated event without the knowledge of Eventing Ireland will:

- forfeit or become ineligible for any regional or grant funding for the year in which it ran.
- have their agreed Eventing Ireland dates removed from the calendar and should not be given a date for a period of 12 months from the date the unaffiliated event ran.

1.7 Volunteering

It is mandatory for all members from the year of their 18th birthday to volunteer and assist in some way at national events, eg: fence judge, scribe etc. Membership to the Society will not be processed unless volunteering roles are confirmed. The Event Organiser will be able to advise volunteering roles required at the event. Volunteers over the age of 75 must advise the event organiser what duties they are able to do.

- Members of Munster, South Leinster, North Leinster and Western Regions must choose **two** events, preferably in their region, to volunteer.
- Members of the Northern Region must nominate **three** events, preferably in their region, due to the different way that events are organised there.

Role fulfillment by all members will be monitored throughout the season. Failure to fulfill your role may result in you and/or your horse being barred from competition or being fined €150. If you are unable to fulfill your volunteering commitment, you must nominate someone on your behalf and contact the local organiser with their details.

A member may nominate a person to volunteer on their behalf. However, if a member's nominated volunteer does not show up (as agreed with the event organiser), the member (if riding) will be prevented from going cross country. Without volunteers, there will be no events.

1.8 Conflict of Interest

To avoid conflict of interest, any person officiating at an Event in, **any capacity**, where there may be a conflict of interest, must declare it to Head Office by noon on Friday before the event at the latest.

1.9 Insurance

It is recommended that all land owners, Eventing Ireland members, including Day Members, have Personal Liability Insurance and health insurance cover. All Eventing Ireland members are advised to have their own Personal Accident Insurance.

Eventing Ireland has a Public Liability Insurance Policy that may include Events organised by, or affiliated to Eventing Ireland, subject to Eventing Ireland obtaining an endorsement to their policy and to the premium being paid by the organiser of the event. Details may be obtained from Head Office of Eventing Ireland.

An application for the affiliation of a national event date will be considered to be acceptance by the landowner/s and organisers that the event will be run under the Insurance Policies of the Society in force at the time the event takes place. The landowner/s and organisers may, at their own discretion and expense, take out any additional or complementary insurance cover that they deem fit. Nothing in this rule detracts from the Society's standing commitment to provide what the Board in its opinion considers, after regularly taking external professional advice and policies being improved to meet changing circumstances, to be the most appropriate specialist insurance cover it can find to offer protection to all sectors of membership and event landowners and organisers

THOSE IN CONTRAVENTION OF THE RULES MAY NOT BE COVERED.**1.10 Photographers and Traders**

Only Official photographers, Content Creators or traders shall be permitted at Eventing Ireland events with full prior permission from the event organiser. Official photographers, Content Creators and traders shall be in possession of valid public liability insurance, a copy of which must be given to the event organiser in addition to other information requested. Please refer to the [Eventing Ireland Filming and Photographic Policy](#) on the website. The TA or EI Steward should always approve camera placement and movement before the competition begins

When members or spectators attend an Eventing Ireland event, members/spectators may be photographed and/or filmed/recorded due to their presence at the event by an official photographer authorised by Eventing Ireland and/or the organiser. The images resulting from the photography, videography or recordings, and any reproductions or adaptations of same, may be used for promotion, publicity and/or other purposes to assist Eventing Ireland in the promotion of its events.

Those who do not wish for their images to be used online must notify the Event Secretary.

Any unofficial photographer/trader who has not been given permission to attend the event by the organiser shall be asked to cease their activity immediately and leave the premises. Unofficial photographs of the event used for commercial gain shall not be published. If they are available on any website or social media pages, the publisher shall be asked to remove them immediately.

If the unofficial photographer/trader is a member of Eventing Ireland, they may be prevented from entering Eventing Ireland future events, and/or membership may be revoked. It will be a matter for the Board to decide the outcome.

Eventing Ireland events are run on private property and therefore the land owner and event organiser can impose these restrictions on all persons entering the event.

USE OF DRONES

Modern photography can greatly enhance our sport. The T/A or EI Steward should always approve Drone operation before the competition begins.

Drones are only to be flown by licensed operators, who must provide risk assessment and a copy of their insurance to the Organiser and EI Steward. The operator must discuss with the EI Steward the flight path and operational plan including the Landing/Home Zone. The take-off is the most intrusive time in the flight of a drone.

The Organiser must inform the EI Office of their plan to allow a Drone to operate at their Event so that a notice is placed on the EI Website page for their Event. A notice must also be placed on the notice board at the Event, informing Athletes, medical personnel, officials and fence judges that there is an approved drone being flown.

Current advice to drone operators is to fly no closer than 40m of the Field of Play (FoP) and at an altitude of no less than 10m when filming alongside a moving Athlete, remain 40m in front of the Athlete on the FoP and at an altitude of no less than 20m when the horse galloping towards the drone. If the flight path is directly overhead of an Athlete, then at an altitude of no less than 40m.

A drone will not have a consistent flight path over members of the public - Commercial Drone Operators Licence – National Laws apply.

1.11 Litter and Respect of Property

It is the responsibility of all Athletes and their travelling party to respect the property of the Landowners and take their litter home or use the litter bins provided.

If you are mucking out your lorry/horse box, ask permission to use the muck heap. It is not up to the landowner or volunteers to pick up discarded tape, muck from your horsebox/lorry or general waste that could have been disposed of correctly.

Event organisers provide litter bins - please use them.

Dumping rubbish will no longer be tolerated and all offenders will receive an on-the-spot fine of €50 or £50 minimum.

Please report littering to the Secretary or EI Steward on the day.

1.12 Stables

At the discretion of the Event Organiser, there will be a €50 refundable deposit for each stable booked onsite. Stables will be checked before the deposit is returned. If stables are not left in a similar condition to which they were presented on arrival, the deposit will be forfeit.

At the request of the organiser, stables booked offsite may also be subject to the €50 or £50 deposit.

1.13 Dogs

All dogs must be kept on leads, held and under control of their handler, at all times - no matter how obedient he / she is normally. Owners will be subject to an on-the-spot fine of €50 or £50 (for each dog) if their dog(s) are reported to be running loose.

1.14 Bikes, Scooters and Buggies/Pushchairs

- The use of Bikes and Scooters, either motorised, electric or push, at national events is at the discretion of the Organiser who has the right to exclude the use of Bikes and Scooters on site at their event, or to allow them to be used in certain areas only.
- However **no** Bikes, Scooters or Buggies/Pushchairs will be allowed on the cross country course once the cross country phase has started. Bikes, Scooters or Buggies/Pushchairs **may be** used outside the confines of the cross country course (ie: outside of the roped area) when the cross country phase has started only with permission of the organiser.
- All Bikes and Scooters must be ridden in a safe manner and should not be ridden at more than 10mph/16kmph anywhere on the Event Site.
- Disciplinary Sanctions (Rule 20.6,) may be taken if members, or their associates, fail to abide by the above rules, or are found to be riding bikes and scooters in an unsafe manner, which may endanger pedestrians and horses.



2 MEMBERSHIP AND REGISTRATION

2.1 Membership

- a) All Athletes and Owners must be either fully paid up members of Eventing Ireland or Day Members (See Rule 2.3).
- b) An annual membership fee will be charged depending on the type of membership purchased. All annual Memberships and Renewals are valid for 12 months from date of purchase and are non-refundable and non-transferable. Upgrades to membership do not extend the membership period. Memberships can be made online via the website or the Membership Form may be downloaded from the website or obtained from Eventing Ireland Head Office.
- c) All memberships must be made prior to the close of entries of the first event at which the Athlete or owners horse is competing.
- d) Corporate or Syndicate Membership is available for two or more owners of one horse, or for companies who use their brand name in the horse name. Corporate/Syndicate Members pay a separate membership fee and must contact Head Office to join.

e) Suspension from Competition

If a member is involved in any criminal activity and is sentenced, whether suspended or not, that person will be suspended from being an Eventing Ireland member and competing at national events for the same period of time. If the member is an international Athlete, this will impact their ability to compete at FEI competitions.

f) Suspension of Membership

A member who has been suspended from all rights and privileges of membership of Eventing Ireland so long as his/her suspension lasts, shall not deal in any capacity with an Eventing Ireland registered horse or pony (eg: as a trainer, adviser, groom) attend any event authorised or affiliated to Eventing Ireland, nor are they allowed to walk the course or have access to the practice areas, or be involved in any respect with an event affiliated to Eventing Ireland.

The Chairman/ Board of Directors or appointed committee may, following receipt of notice of a concern and/or at any point prior to the determination of a complaint, suspend the membership of a Member of any part or parts of the rights or benefits of a Member if it reasonably believes that:

- i. Children, young people or adults may be at risk;
- ii. It is necessary for the protection of other Members, including the Respondent;
- iii. Allegations against the Respondent would, if established and upheld, in the sole discretion of the Chairman/Board of Directors or appointed committee as appropriate, the reputation of Eventing Ireland could be harmed if the Respondent continues to act as a Member
- iv. In the sole discretion of the Chairman/Eventing Ireland Appointee/Board of Directors, the reputation of Eventing Ireland could be harmed if the Respondent continued to act as a Member
- v. The continued involvement of the Member might impede inquiries/investigation. Such decision to suspend must be approved in writing by three members of the Board or relevant appointed committee.

An official (judge, coach, trainer, steward, members of the Disciplinary Committee or a Course Designer) may be suspended from all rights and privileges of membership if charged with any sexual offence relating to children or vulnerable young adults pending a full investigation by the Disciplinary Committee and/or the conclusion of any criminal Safeguarding/Disciplinary Panel in writing.

Suspension under this Rule, while a serious matter, is not a disciplinary sanction and should not therefore be viewed as a sign of guilt. The disciplinary hearing shall take place as soon as reasonably practicable, following notification of the suspension having been given to the member concerned.

2.2 Horse Registration

- a) All Horses and Ponies must be registered to compete with Eventing Ireland either by annual registration or Day Registration (See Rule 2.3).
- b) The owner of any Horse/Pony must be 18 years of age or over.
- c) An annual registration fee will be charged and can be made either online via the website or the registration form may be downloaded or obtained from the Eventing Ireland Head Office
- d) Registrations are valid for 12 months from date of purchase and are non-refundable and non-transferable. Upgrades to registrations expire on the original date of purchase. Registrations are invalid if the owners membership expires before the registration renewal date.
- e) On registration, each horse will be allocated a unique non-transferable number. Eventing Ireland reserves absolutely the right to refuse to register a name of a horse. A horse may only be entered in its registered name and with the number allocated on registration.
- f) All horses must have a national passport in which the animal is named and the correct owner must be displayed in the passport. Marking Charts must be updated from time to time to include any acquired marks. If a horse has an FEI Passport (and the name is different to that on the national passport), the FEI Passport name will be recorded on the Eventing Ireland website.
- g) All horses and ponies registering with EI must provide a microchip number on the database. Anyone not providing that information may be subject to a fine**
- h) To register a new horse, a copy of the naming page of the national or FEI passport must be submitted to the Eventing Ireland Head Office along with pages showing the breeding and the owner. All new pony registrations must also submit a copy of the height measurement certificate. The horse will not be able to enter an event to compete unless this information has been checked by Head Office.
- i) If a horse/pony is measuring at 148cm, it may be registered as **either** a horse or a pony, at the discretion of the owner. If the animal has recorded results for the current calendar year, the registration type may not be changed during that same year.
- j) Changes of ownership of a registered horse must be notified to Eventing Ireland in writing, by the purchaser, before the horse can compete in an Official Event.

2.3 Day Membership and Day Registration

Members and Non-members may apply for Day Memberships and Day Registrations to enable them and their horses to compete in Eventing Ireland competitions. Day memberships can only be used in EI110, EI105, EI100, EI90 and EI80 level classes. A Day Membership and Registration effectively registers one Athlete and horse for a competition. The owner, if different from the Athlete, is not registered.

Day Membership and Registration fees are in addition to the Entry Fee.

Like full members, a Day Member must adhere to the Eventing Ireland rules as they are effectively members of Eventing Ireland for the Day of Competition. The horse is also effectively registered with Eventing Ireland for the Day of Competition.

All horses/ponies competing on a Day Registration must have the correct Passport – which must accompany the horse/pony to ALL Competitions. Please see Passport Rule 17.1.

The naming page of the passport for an unregistered horse competing on a day registration must be sent to Head Office.

2.4 Day Memberships and Registrations for EI105, EI100, EI90 and EI80 Classes

Athletes must be in the year of their 12th birthday in order to be eligible to compete on a Day Membership. There is no restriction on the number of day tickets at these levels.

Note: The initial Day Memberships for under 18's will not be accepted until a signed parental consent form, a signed Letter of Competency form and a copy of the birth certificate and a copy of the naming page of the horse's passport have been received by Head Office

All underage Athletes, having submitted the required paperwork and who have been accepted and registered by Head Office to ride on a day membership, will be able to make entries online for the same combination at the same level. If the Athlete wishes to compete on a different horse, the process must be completed for each different horse.

2.5 Day Memberships For EI110 Classes

- Athletes must be in their 18th year or over
- Athletes must have **completed** at least 3 Eventing Ireland EI100 competitions or higher on the horse that will be ridden on the EI110 Day Membership within the last 12 months, with 3 EI100 or EI105 clear xc jumping rounds and no more than 16 sj jumping penalties in total.
- and/or have completed at least 5 EI100 or EI105 competitions or higher on any horse in the last 2 years with 3 EI100 clear xc jumping rounds and no more than 16 sj jumping penalties in total on any horse.
- Overseas-based Athletes, or Athletes completing EI100 competitions from overseas National Federations, must supply a performance record confirming similar qualifications with their application.

2.6 Horse Day Registrations for EI110 Classes

- Applicable for unregistered horses with Eventing Ireland but have completed at least 3 Eventing Ireland EI100 or EI105 competitions or higher in the last two years with the specified Athlete with 3 EI100 or EI105 clear xc jumping rounds with no more than 16 sj jumping penalties per event.
- Horses must be five years old or over
- Day Registrations are not transferable and can only be applied for in writing to Head Office

The number of Day Tickets at the EI110 level is limited to a maximum of 3 (as a combination) in any one year.

Please note: Points are not awarded to those competing on Day Memberships and/or Registrations even if they have been placed. If a day member or horse subsequently registers with Eventing Ireland, points are not awarded retrospectively.

3 HORSE TRIALS/EVENTS

The two types of Events are:

3.1 One Day Events

The three tests normally take place in one day.

The Event Organiser will set the maximum number of entries for their event on the website.

NB: In the case of large numbers of entries it may be necessary to extend the timetable to an extra day; the event will still be regarded as a One Day Event.

3.2 Three Day Events

This is the ultimate form of Eventing competition and the three tests invariably take place on separate days. The first day is confined to Dressage. (Sometimes a second Dressage day is required depending on number of entries). The second day's test is the Cross Country. The object of the third day's jumping test is to prove that, after the test of the second day, the horse has retained the suppleness, energy and obedience necessary to complete.

3.3 Event Details

Eventing Ireland publishes upcoming events its website www.eventingireland.com/events.aspx

Event Information includes:

- The name of the Organiser
- Contact details for Event Secretary
- Name of Cross Country Course Designer
- Name of the Eventing Ireland Steward and Technical Adviser
- Entry Fees (See Rule 3.15)
- Opening/Closing date of entries
- Withdrawals / Refund information
- Classes (including grades and dressage tests)
- Dressage Times
- Stabling details and Accommodation details (if requested)
- Location/directions

3.4 Event Programmes

a) All Event Programmes (whether printed or paperless/electronic) must include the following:

- Statement that the Event is held under the rules of Eventing Ireland
- Timetable of Classes and Tests
- List of Entries with Score Sheet
- List of Officials including the Organiser, Eventing Ireland Steward, Course Designers, Technical Adviser, Judges, Veterinary and Medical Officer and/or Paramedics
- Disclaimer of Liability (see Rule 3.6 Disclaimer of Liability)
- Health and Safety Statement. (see Rule 3.5 Health and Safety)
- Organiser's Reservation of Rights (see Rule 3.7 Reservation of Rights)

b) The following additional items should be included:

- Brief rules and system of scoring
- Plan of Cross Country Course (and/or Fence descriptions and/or diagram of Cross Country course/s (See Rule 23.3)
- Rules on forbidden assistance
- Request for dogs to be kept on leads
- Sponsors and Advertisements

3.5 Health and Safety

The following statement must be included in all Event programmes.

"The Organiser of this Event has taken reasonable precautions to ensure the health and safety of everyone present. For these measures to be effective, everyone must take all reasonable precautions to avoid and prevent accidents occurring and must obey the instructions of the Organiser and all the officials and stewards. Spectators are responsible for their own safety and must keep to designated viewing areas".

The Eventing Ireland Steward may take such action as he feels necessary to protect the health and/or safety of horses and/or Athletes, or anyone attending an Event. Organisers must require all drivers and passengers on All Terrain Vehicles, or riders of motorcycles, to wear suitable protective headgear and must not allow passengers to be carried on such vehicles (unless designed or specifically adapted for the purpose) except in an emergency.

All Athletes must ensure that they and their horses are fit and competent to compete in the class for which they have entered.

Please refer to Eventing Irelands Health and Safety Statement

<https://www.eventingireland.com/app/uploads/2026/02/EI-HS-safety-policy-statement.pdf>

3.6 Disclaimer of Liability

Save for death or personal injury caused by the negligence of the organisers or anyone for whom they are in law responsible, neither the organisers of any Event to which these rules apply, nor Eventing Ireland, nor any agent, employee or representative of these bodies accepts any liability for any accident, loss, damage, injury or illness to horses, owners, Athletes, spectators, land, cars, their contents and accessories or any other person or property whatsoever, whether caused by their negligence, breach of contract or in any other way whatsoever.

3.7 Reservation of Rights

The Organiser has the right:

- a) To cancel any class or event (See Rule 3.9 Event Cancellation)
- b) To refuse an entry without giving a reason
- c) To divide any class
- d) To transfer Athletes between sections of a class
- e) Amalgamate a class (See Rule 3.14 Amalgamation)
- f) To alter the advertised times published on the Eventing Ireland website

3.8 Entries/Substitutions of Horse and/or Athlete

- a) An entry for each horse and Athlete must be completed in full, signed/authorised if online, by the owner or his authorised agent and state that the horse is registered with Eventing Ireland.
- b) All entries to an event can be made online and must be received either before the maximum number of entries has been reached (as stated on the Event Entry page on the website) or by 12 noon at the stated Close Of Entry date, whichever comes first. (Please refer to Rule 3.19 Allocation of Entries from Waitlist).
- c) No entries will be taken by email or telephone on the day of close of entries. It is the responsibility of the owner/Athlete to enter an event on time.
- d) Making an entry in any event to which the Rules for Eventing Ireland apply constitutes acceptance of these rules.
- e) Date of close of entries is at the discretion of the Event Organiser and will be published online
- f) Full Entry Fees (as detailed on the website) must accompany the Entry **IN THE APPROPRIATE CURRENCY.**

- g) Any entry or substitution of horse and/or Athlete for a national class sought after the time for receipt of entries has passed, as detailed on the website, will be deemed a Late Entry. An automatic Late Entry Fee of €15/£15 per entry will be charged on top of the published entry fee.
- h) Members are able to make their own late entries after the close of entries for a limited time only (as stated on the website) and may vary from event to event.
- i) Late entries will only be accepted if the event is not already full and only with the consent of the Organiser **which will be sought by Head Office only**. The time of closing of acceptance of Late Entries will be at the discretion of the Organiser and Head Office.
- j) Members are able to make their own changes to their entries, free of charge, via the website, ie: change Athlete or horse (if qualifications have been met), change class (a charge will be applied if there is a difference in entry fee) and withdraw their entry free of charge if done before 12 noon on the Monday before the event.
- k) **Strictly no changes will be made to entries after 12 noon on the Friday before the event – no exception.** A fee of €10 plus admin fee will be charged for **each change made after close of entries and before 12 noon on Friday.**
- l) Horses may compete in only one class at an Event.

3.9 Event Cancellation

Only the Eventing Ireland Steward or their nominated representative may advise Head Office, in writing, of cancellation of an event. An Event is deemed to be cancelled when it does not run on the date for which it was fixed. If it is rescheduled for another date, it is deemed to be a new fixture and the rules concerning entries and cancellation apply to it afresh as a new event. No individual entries may be transferred from one event to another unless Rule 3.11 applies.

3.10 Refund of Entry Fee after an Event Cancellation

- a) If cancellation is advised before 0930 hours, Thursday for a Saturday Event and by 0930 hours Friday for a Sunday OR Monday event, a Full Refund of entry fee, less any card charges will apply to all Athletes.
- b) If cancellation occurs within two days of the event, (ie. after the above listed times) a Refund of entry fees, less €15/£10 Administration charge – (the Administration charge will go to the organiser
- c) less any card charges) will apply to all Athletes.
- d) In the event of an Event being abandoned (ie: after starting) for whatever reason there will be no refund.

3.11 Transfer of Venue/Entries to another Venue

Only under **exceptional circumstances**, and only with the approval of the region, may an event transfer an event to another suitable location **within the same region on the same date**. The following conditions will apply:

- Transfer of Venue will only apply after the close of entries when the advertised event is unable to run safely
- The Eventing Ireland Steward or nominated representative must notify Head Office as soon as possible in writing of this change giving the full reason, which will be published on the Eventing Ireland website and social media pages
- All entries for the cancelled event will be transferred to the new venue
- The transferred event must hold the same classes as the cancelled event

- Any Athlete who does not wish to compete at the new location will be entitled to a full refund (less administration charges as per Rule 3.10 (b). Every endeavour will be made to contact the Athlete by the event organiser or their representative by email and/or telephone.
- The Athlete may also contact Head Office either by telephone or email and request a refund
- No refunds will be made after noon on the Friday prior to the event
- No entries can be transferred to any other event
- Entries to the transferred event will not re-open
- At the discretion of the event organiser, only those on the existing waitlist may be entitled to make an entry, to facilitate any class vacancies made by refunds

3.12 Declarations

Making an entry for an event will be considered a declaration to start. Athletes who withdraw must notify Head Office according to the procedure in the relevant schedules. Failure to notify withdrawal may make an Athlete liable to suspension from Eventing Ireland under disciplinary procedure and their entry fee[s] will be forfeited.

3.13 Withdrawals and Refunds

In the event of having to withdraw a horse from the nominated competition having already submitted an entry, the entry fee and/or day ticket will be refunded if withdrawn before the date and time of close of entries stated on the Event page of the website.

Refunds do not apply after close of entries.

Only in exceptional circumstances will refunds be made by Head Office and only at the discretion of the Event Organiser, if a vet or medical certificate is sent by email to Head Office by noon on the Thursday before the event. Please contact Head Office in the first instance.

Athletes who are not present for their dressage test will be shown as DNS (Did Not Start) in the results.

3.14 Amalgamation of Classes

Event Organisers have the right to amalgamate classes with entries of 6 or less into the main class at the same level without the entrants having to be consulted. The exception to this will be E1110P which will always have its own class regardless of numbers of entries.

Athletes not wishing to compete in the amalgamated class will have the right to withdraw and receive a full refund but this must be done by noon on the Thursday before the event. It is the Athlete's responsibility to contact Head Office either by telephone or email if they wish to withdraw.

In the situation of classes being amalgamated there will be extra prize (if monetary, the same as the lowest prize awarded for the placings or in kind as according to the rules) and rosette for the leading Amateur, Young Rider, Junior and Pony Athlete placed outside the class prizes, so long as they finish in the top 25% of the starters. Athletes will only be eligible for one prize in an amalgamated class.

3.15 Start Fees

Start fees are at the discretion of the organiser. Start Fees must be advertised on the website when entries open.

Start fees must be collected at the event on the day of the event.

3.16 Order of Phases

The dressage test will always be completed first, followed by either the Cross Country or Show Jumping.

Where two or more of the phases take place on the same day, the horse must be allowed a minimum of 30 minutes between them. However, under certain circumstances, (ie: multiple Athletes), the time allowed may be reduced.

3.17 Relative Influence

The relative influence on the whole competition exerted by the Dressage should be slightly more than that exerted by the Show Jumping, but considerably less than that exerted by the Cross Country.

3.18 Classification

The same horse and Athlete combination must complete all three tests and elimination from one test involves elimination from the whole competition. If technically eliminated from Dressage and Show Jumping the Athlete may ride across country solely at the discretion of the Eventing Ireland Steward (**subject to Rule 10.6 Technical Elimination**)

3.19 Allocation of Entries from Waitlist

Should the maximum entries for an event be reached, a Waitlist will come into immediate effect.

Entries from the waitlist will be allocated in the order in which they were received. Waitlist entries will only be accepted if received by email to headoffice@eventingireland.com stating event, name of Athlete, name of horse/pony and class type.

Head Office and the Event Organiser reserves the right to select entries from this Waitlist into the event if spaces become available.

3.20 Appearance Money

No Athlete shall offer or receive any form of payment or inducement to enter or compete at any Eventing Ireland Events that is not available to all other Athletes in that event except for any official allowance paid by or with the authority of Eventing Ireland.

3.21 Hors Concours (HC)

An Hors Concours Athlete must observe exactly the same rules as a regular Athlete, but no prize can be awarded nor points earned for participating Hors Concours. Hors Concours Athletes accepted at entry will be recorded as such in the programme and may be asked to compete either first or last in their section. Athletes permitted to continue Hors Concours may compete at their allotted time, but must in each case be indicated by HC on the scoreboard.

HC Athletes do not get points nor do they count for the purposes of awarding points, however HC Athletes are awarded an MER for the level of class

3.22 Order of Starting

The order of starting will be drawn after entries have been received but Athletes with more than one horse to ride, and those with long distances to travel may be seeded, at the discretion of Head Office.

Where possible the order of starting drawn up after close of withdrawals will be adhered to throughout the competition unless the Show Jumping Test takes place last, in which case the order of starting may be changed at the discretion of the Organiser. The Cross Country will run in numerical order, unless under exceptional circumstances where permission has been granted to run out of order, eg. to facilitate multiple rides. **Note: Athletes must, under penalty of elimination, be prepared to start in their numerical order. Athletes maybe eliminated if they delay the completion of their class or delay the start of the next class.**

The order of starting and the times at which Athletes will be required to start will be posted on the Eventing Ireland website by 4.00pm on the day preceding the event. Starting times should also be available to Athletes by telephone at the times posted on the Eventing Ireland website.

If in exceptional circumstances, it is necessary to alter the timetable, all reasonable steps must be taken to inform Athletes, when they must, under penalty of elimination, be prepared to start at their revised times. However, any Athlete that is ready, may be started earlier at the discretion of the starter.

3.23 Athlete Numbers

For the purpose of identification, Athletes must wear numbers on their front and back during the Cross country. In the Dressage and Show Jumping phases the type of number worn is at the discretion of the organiser. The Event Secretary will either supply Athlete numbers or it is the Athlete's responsibility to print their numbers (2 per horse) from the template given. It is the Athlete's responsibility to own/wear a bib and to ensure that the correct number is worn, and that it is clearly visible at all times.

Riding wearing the wrong bib number will warrant a verbal warning for a first offence only. A fine of €20 / £20 or yellow card will be issued for a second offence.

3.24 Orders from Officials

Athletes and Owners of competing horses and their grooms must obey any order or direction given to them by any responsible official and they must, in particular be careful not to do anything liable to upset or hinder the progress of the competition. Failure to comply with this rule may entail elimination and reporting to Eventing Ireland Head Office.



Plusvital

Powered by Science

Science-based supplements for #thevitaledge



Sport Syrup
Contains essential vitamins, minerals and amino acids PLUS prebiotics to support the performance horse.

Chillax
Helps to calm excitable horses in stressful conditions.

MyoMax EQ
Scientifically formulated pelleted supplement to support the development of topline and lean muscle mass.



Visit plusvital.com to shop all of our products online





*David
Foster*
INJURED RIDERS FUND

**The Only Irish Fund for
Injured Event Riders**



David
Foster
INJURED RIDERS FUND

Make a Donation

Click Here to make a
donation using Paypal

Contact Jessie on 087 6531623

www.davidfosterinjuredridersfund.ie

EVENT CLASSES AND GENERAL GUIDANCE

4 PARTICIPATION OF ATHLETES AND HORSES

- a) All Athletes, except Pony Athletes, must be aged 14 years or over. All Owners and Athletes must be members of Eventing Ireland.
- b) **All Athletes are responsible for ensuring that they are eligible and competent to compete in any class entered. It is likewise the responsibility for parents and guardians of Junior and Pony Athletes to ensure that their child or ward is both eligible and competent.**
- c) Foreign Athletes and horses may be admitted, with the permission of their National Federation.
- d) Foreign Athletes must be in possession of a licence issued by the National Federation of their home country before applying for membership of Eventing Ireland, as well as to register a horse.
- e) Foreign Horses Imported by Irish Nationals will be automatically classified as Advanced. However on production of a certificate from The National Federation of the Country of Origin, indicating its record in overseas Events, the horse may be re-graded at the discretion of Eventing Ireland. When Irish horses, which have competed in foreign national competitions, are re-imported, their results in overseas competitions must be declared and they will be graded at the discretion of Eventing Ireland.
- f) Foreign Owned Horses. A foreign owned horse will be classified as Advanced unless a certificate from the National Federation of the country of origin, giving its record in overseas Horse Trials is sent to the Eventing Ireland Office, when the horse may then be re-graded at the discretion of Eventing Ireland.
- g) A Horse purchased in Ireland by a foreigner will continue to be graded according to the points it has been awarded, provided it has not competed as a member of a team or nominated individual at the Olympics games, FEI Championships, in which case it will be automatically be classed as Advanced level (EI115), and until it is exported, may continue in any class from which it is not barred under Rule 8

5 DEFINITION OF ATHLETE MEMBERSHIP TYPES**5.1 Senior Athletes**

- a) Senior Athletes must be a fully paid up member of Eventing Ireland.
- b) A Senior Athlete may compete from the beginning of the calendar year in which he reaches the age of 18 (eighteen).
- c) A Senior Athlete may compete in all eligible classes

5.2 Restricted Athletes

- a) Restricted Athletes must be fully paid up members of Eventing Ireland
- b) Restricted Athletes may compete from the beginning of the calendar year in which he reaches the age of 18 (eighteen)
- c) Restricted Athletes are registered to compete in EI105, EI100, EI90 or EI80 classes only
- d) Restricted Athletes may upgrade to Full Senior Membership at anytime during the season

5.3 Amateur Athletes

- a) An amateur Athlete is one who receives no income from riding, producing horses or coaching Athletes.
- b) Athletes may compete in any amateur competition from the beginning of the calendar year in which they reach the age of 21 (twenty one).
- c) Amateur Athletes must tick the amateur box when renewing membership to identify themselves as amateurs or they will not be able to enter the Amateur class
- d) Amateur Athletes must complete the questionnaire and send to Amateur Committee to confirm their amateur status
- e) Amateurs may register a maximum of three horses in any one season in their own name

- f) The amateur Athlete must comply with the ethos of the amateur class at the discretion of the Amateur Committee. Anyone who feels they are technically outside these qualifications but could qualify within the spirit of the amateur class may apply in writing to the Amateur Committee for consideration prior to entering any Amateur Classes. The decision of the Amateur Committee is final.
- g) An Amateur Athlete who competes in a CCI3*-S or L class or above will not be permitted to ride in EI110 Amateur classes or below on that horse for the remainder of that calendar year.
- h) Amateur Athletes will not be permitted to compete in classes over 1.30m at SJI or equivalent.
- i) Amateur Athletes who are in HSI High Performance Training or on Athlete Bursaries in the current season will not be allowed to compete as in Amateur Classes
- j) No Athletes are allowed to compete in Amateur classes for a season after they have competed for their country on any team or nominated as an individual
- k) All Amateur Rules are policed by the Amateur Committee. Full details regarding eligibility as an Amateur can be found under the 'Amateur Section' on the Eventing Ireland website.

5.4 Young Rider Athletes

- a) Young Rider Athletes must be fully paid up members of Eventing Ireland.
- b) A Young Rider Athlete may compete from the beginning of the calendar year in which they reach the age of 18 (eighteen) until the end of the calendar year when they reach 21 (twenty one)
- c) A Young Rider Athlete may compete in EI80, EI90, EI100, and higher classes where appropriate.

5.5 Junior Athletes

- a) Junior Athletes must be fully paid up members of Eventing Ireland.
- b) A Junior Athlete may compete from the beginning of the calendar year in which they reach the age of 14 (fourteen) until the end of the calendar year when they reach 18 (eighteen)
- c) Junior Athletes may compete in the EI80, EI90, EI100J and higher classes where appropriate.
- d) All new Junior combinations who join Eventing Ireland must provide a copy of their birth certificate, a Competency Form signed by an approved riding instructor or HSI Trainer (see Rule 5.9) and a Parental Consent Form before being allowed to compete. A [Competency Form](#) can be downloaded on the Eventing Ireland website.
- e) A new Competency Form must be completed if the Athlete is riding a new horse and will be competing as a new combination as per point (d) above.
- f) Only an approved Level 2 or 3 HSI Eventing coach or an approved Senior Athlete (who is not their trainer) may upgrade a junior combination to EI110J level. See Rule 5.9
- g) All upgrades must be made at least 10 days prior to the event they wish to compete at the new level. There will be no exceptions
- h) It is forbidden for a Junior Athlete to compete in two full competitions on two consecutive days on the same animal

Upgrading – Junior Classes

Class	Recommended Minimum Requirement
EI100J to EI110J	3 cross country clear jumping rounds in the current or preceding year in an EI100J or EI105– as a combination
EI90J to EI100J	3 cross country clear jumping rounds in the current or preceding year in an EI90 – as a combination

5.6 Pony Athletes

- a) Pony Athletes must be fully paid up members of Eventing Ireland.
- b) A Pony Athlete may compete from the beginning of the calendar year in which they reach the age of 12 (twelve) until the end of the calendar year when they reach 16 (sixteen)
- c) Pony Athletes may compete in the EI80, EI90P, EI100P and EI110P classes (See Rule 5.8)

- d) All new pony combinations who join Eventing Ireland must provide a copy of their birth certificate, a Competency Form signed by an approved riding instructor or EI/HSI Trainer and a Parental Consent Form before being allowed to compete. A [Competency Form](#) can be downloaded on the Eventing Ireland website.
- e) A new Competency Form must be completed if the Athlete is riding a new pony and will be competing as a new combination. The competency form must be completed as per point (d) above.
- f) Only an approved Level 2 or 3 HSI Eventing coach or an approved Senior Athlete (who is not their trainer) may upgrade a pony combination to EI110P level. See Rule 5.9
- g) A Pony Member, if of the appropriate age, may compete in Junior classes without influencing their status as a Pony Athlete. They may compete Internationally at a Championship as **either** a Junior or Pony Athlete, but not both in the same year.
- h) All upgrades must be made at least 10 days prior to the event they wish to compete at the new level. There will be no exceptions
- i) It is forbidden for a Pony Athlete to compete in two full competitions on two consecutive days on the same animal

5.7 Definition of Pony Classes

EI110P (Grade B):	Open to EI110P combinations only
EI100P (Grade C):	Open to EI110P and EI100P combinations only
EI90P (Grade D):	Open to all Pony combinations

5.8 Upgrading – Pony Classes

Class	Recommended Minimum Requirement
EI100P to EI110P	3 cross country clear jumping rounds in the current or preceding year in an EI100P or EI105 – as a combination
EI90P to EI100P	3 cross country clear jumping rounds in the current or preceding year in an EI90P – as a combination

All pony EI90 combinations must seek permission from their Regional Co-Ordinator to move up to EI100P (see Appendix S)

5.9 Definition of Approved Eventing Coaches

An approved Riding Instructor or HSI Trainer who has knowledge and experience of cross country may sign off Competency Forms for Athletes competing at EI80-EI100

Only an approved Level 2 or 3 HSI Eventing coach or an approved Senior Athlete (who is not their trainer) may upgrade a combination from EI100J/P to EI110J/P level. Attaining the recommended minimum requirement does not automatically allow the combination to upgrade.

***An approved Senior Athlete is one who has competed at 4* level and above and who has obtained and currently holds the necessary Child Safeguarding paperwork, insurance and first aid certificates.*

The Competency Form as mentioned in Rules 5.5 and 5.6 must be completed and submitted to the EI Head Office before an entry to any class is accepted. **All upgrades must be made within 10 days of the event they wish to compete at the new level. There will be no exceptions.**

5.10 Underage Grading Categories

The grading levels for Junior and Pony Athletes and horses/ponies as follows:

Grade	Junior	Pony
A	EI115	n/a
B	EI110	EI110
C	EI100	EI100
D	EI90 & EI80	EI90 & EI80



6 CLASSES AND GENERAL GUIDANCE

An Event may run any of the following classes. (As listed in Rule 6.2) Unless otherwise stated, all EI80, EI90 and EI100 classes include EI90P, EI90A, EI100P, EI100A, EI100J

6.1 ERQI Information

The **EquiRatings Quality Index (ERQI 2.0)** is an indicator of successful show jumping and cross-country form using Athlete results data from national events. An ERQI can be seen in the Horses/Ponies tab in the member account for animals that have been registered.

The ERQI will be updated after every event and will show during the entry process after selection of the class, Athlete and horse and will form part of the Qualifying Criteria when entering a class.

The definition of ERQI's is listed below:

ERQI 2.0 Category	
A++	The ERQI Rating for this level indicates excellent form
A+	The ERQI Rating for this level indicates very good form
A	The ERQI Rating for this level indicates above average form
B	The ERQI Rating for this level indicates average form
C	The ERQI Rating for this level indicates below average form
D	The ERQI Rating for this level indicates low form for this level
E	The ERQI Rating for this horse is not sufficient for this class
Pending	This horse has not yet recorded enough cross country runs to be assigned an ERQI Rating. Three runs are required in order to be attributed a rating.

6.2 Class Types and Qualifying Criteria

Class Type	Criteria
EI120	<ul style="list-style-type: none"> Athletes must be full members Horses must be registered and 7 years or over Restricted to horses with 51 points or more OR who have obtained 6 MERs at EI115 and/or CCI3*S/L ++. ERQI must be green or amber at EI120 as per ERQI table above Advance points awarded as per Rule 8
EI115 Adv	<ul style="list-style-type: none"> Athletes must be full members Horses must be registered and 6 years or over Restricted to horses with 21 points or more OR who have obtained 6 MERs at EI110 and/or CCI2*S/L ++ Dressage and Show Jumping is of Advanced Standard and Cross Country is of Intermediate Standard. ERQI must be green or amber at EI115 as per ERQI table above Intermediate points awarded as per Rule 8
EI115 Open	<ul style="list-style-type: none"> Athletes must be full members Horses must be registered and 6 years or over Restricted to horses with 11 points or more OR who have obtained 6 MERs at EI110 and/or CCI2*S/L ++ ERQI must be green or amber at EI115 as per ERQI table above Intermediate points awarded as per Rule 8
EI115	<ul style="list-style-type: none"> Athletes must be full members Horses must be registered and 6 years or over Restricted to horses with 11 – 50 points OR who have obtained 6 MERs at EI110 and/or CCI2*S/L ++ FEI A or B categorised Athletes may move a horse up to EI115 level once the horse has achieved a minimum of 8 points. The Athlete must contact Head Office before close of entries in order to make the entry ERQI must be green or amber at EI115 as per ERQI table above



Class Type	Criteria
	<ul style="list-style-type: none"> Intermediate points awarded as per Rule 8
EI115J	<ul style="list-style-type: none"> Junior Athletes must be full members and have approval from their Junior HSI to compete in this class Horses must be registered and have a minimum of 11 points OR who have obtained 6 MERs at EI110 and/or CCI2*S/L ++ and approved as a combination by the Youth HSI HP Manager Horses must be 6 years old or over Run at Intermediate level (or as advised by the Junior HSI HP Manager) ERQI must be green or amber at EI115 as per ERQI table above Points awarded as per Rule 8
++ Please contact Head Office before close of entries if you cannot make an entry to the above classes. All MERs must be clear of Cross Country jumping penalties	
EI110 Open	<ul style="list-style-type: none"> Athletes must be full members Open to all registered horses with 21 points or more and 5 years old and over Dressage, Show Jumping and Cross Country is EI110 standard ERQI must be green or amber at EI110 as per ERQI table above No points awarded
EI110J	<ul style="list-style-type: none"> Open to Junior combinations who have been assessed and approved by a Level 2 or 3 Eventing Coach or an approved senior Athlete before entering their first EI110J (see 5.5e) Horses must be registered and 5 years old or over ERQI must be green or amber at EI110 as per ERQI table above Points awarded as per Rule 8
EI110	<ul style="list-style-type: none"> Athletes must be fully paid up members Open to all registered horses with 0-20 points Horses must be at least 148cm and 5 years old or over A pony may be ridden by an adult and must be a minimum of 143cm and 5 years of age ERQI must be green or amber at EI110 as per ERQI table above Points awarded as per Rule 8 Day Memberships/Registrations do not receive points
EI110P	<ul style="list-style-type: none"> Open to fully paid up Pony Athletes from the beginning of their 12th year until the end of their 16th year Pony Athlete combinations who have been assessed and approved by a Level 2 or 3 Eventing Coach or an approved senior Athlete before entering their first before entering their first EI110P (see 5.6f) Ponies must be registered Ponies must be least 142cm and 5 years old and over Dressage, Show Jumping and Cross Country is of EI110 standard or as advised by the HP Pony Manager ERQI must green or amber at EI110 as per ERQI table above No points awarded
EI110 Amateur	<ul style="list-style-type: none"> Open to Athletes in their 21st year and over who are Full Members - Amateur Box must be ticked Non-members must apply to Head Office for Day Memberships or day registrations Open to registered horses with any points Horses must be least 148cm and 5 years old or over A pony ridden by an adult must be a minimum of 143cm and 5 years of age A EI110 Amateur Combination (same horse & Athlete) is allowed to compete in three (3) EI115 classes in any year without affecting their amateur status. The same combination may also drop down to EI100 amateur class but not down to an EI90 amateur class.

Class Type	Criteria
	<ul style="list-style-type: none"> An amateur Athlete who completes more than 3 x EI115 classes and one CCI3*L/S class in any year may not compete as an amateur Athlete for the rest of that year. A EI110 amateur Athlete may also ride other horses in any amateur classes provided such horse has not competed above the level for which it is being entered. A EI110 amateur Athlete who wins 10 competitions on the same horse in one season, must move to the equivalent non-amateur class for the rest of that year. However, the combination may compete in the EI110 Amateur National Championship class. ERQI must be green or amber at EI110 as per ERQI table above Completion points only will be awarded as per Rule 8 Day Memberships/Registrations do not receive points
EI105	<ul style="list-style-type: none"> Open to Athletes from the beginning of the year of their 12th birthday who are Full or Restricted members or those on Day Memberships only Open to all registered horses with any points Horses must be at least 148cm and 5 years old or over A pony may be ridden by an adult and must be a minimum of 143cm and 5 years old or over ERQI must be green or amber at EI100 as per ERQI table above No points awarded
EI100	<ul style="list-style-type: none"> Open to Athletes from the beginning of their 19th year who are Full or Restricted Members or those on a day membership Open to registered horses or on day registrations which have up to 10 points. Horses with 11 points or over will be HC Horses must be at least 148cm and 4 years old or over. A pony ridden by an adult must be a minimum of 143cm and 5 years of age ERQI must be green or amber at EI100 as per ERQI table above No points awarded
EI100J	<ul style="list-style-type: none"> Open to a Junior Athlete from the beginning of the calendar year in which they reach the age of 14 (fourteen) until the end of the calendar year when they reach 18 (eighteen), who are Full or Restricted Members or those on a day membership Underage Athlete combinations must have submitted a Competency Form and be approved by their Regional Coordinator Horses must be at least 148cm and 4 years of age or over A pony must be a minimum of 143cm and 5 years old or over No horse which has competed in a CCI5* competition in the current or preceding year is eligible for this class. ERQI must be green or amber at EI100 as per ERQI table above No points awarded
EI100P	<ul style="list-style-type: none"> Open to Pony Athletes from the beginning of their 12th year until the end of their 16th year who are Full or Restricted Members or those on a day membership Underage Athlete combinations must have submitted a Competency Form or be approved by their Regional Coordinator Open to ponies, either registered or on a day registration. Ponies must be least 138cm, and 5 years old or over ERQI must be green or amber at EI100 as per ERQI table above No points awarded.
EI100 Amateur	<ul style="list-style-type: none"> Open to Athletes in their 21st year and over who are Full or Restricted Members or those on day memberships - Amateur Box must be ticked Horses must be at least 148cm and 4 years old or over Open to horses with any points either registered or on day registrations A pony ridden by an adult must be a minimum of 143cm and 5 years old

Class Type	Criteria
	<ul style="list-style-type: none"> • An EI100 amateur Athlete may compete in 4 amateur EI110 classes and revert to EI100 Amateur in the same year on the same Athlete/horse combination. Amateur EI110 Athletes may compete in EI100 amateur classes on a different horse. • An EI100 amateur Athlete who wins 10 competitions on the same horse in one season, must move to the equivalent non-amateur class for the rest of that year. However, that combination may compete in the EI100 Amateur National Championship class. • ERQI must be green or amber at EI100 as per ERQI table above • No points awarded
EI90	<ul style="list-style-type: none"> • Open to Athletes from the beginning of their 12th year who are Full or Restricted Members or those on day memberships • Underage Athletes - combinations must have submitted a Competency Form or be approved by their Regional Coordinator • Open to horses, either registered or on a Day Registration which have up to 10 points. Horses with 11 points or over will compete HC • Horses must be least 148cm, and 4 years old and over • A pony ridden by an adult must be a minimum of 143cm and 5 years of age • ERQI must be green or amber at EI90 as per ERQI table above • Athletes with a Red ERQI must obtain a XC Competency Form as per Rule 10.4 before being able to compete at this level or can compete at EI80 • No points awarded
EI90 Amateur	<ul style="list-style-type: none"> • Open to Athletes in their 21st year and over who are Full or Restricted Members or those on day memberships - Amateur Box must be ticked • Horses must be at least 148cm and 4 years old or over • Open to horses with any points either registered or on day registrations • A pony ridden by an adult must be a minimum of 143cm and 5 years and over • An EI90 amateur Athlete may compete in 4 EI100 amateur classes and revert to EI90 Amateur in the same year on the same Athlete/horse combination. Amateur EI100 Athletes may compete in EI90 amateur classes on a different horse. • An EI90 amateur Athlete who wins 10 competitions on the same horse in one season, must move to the equivalent non-amateur class for the rest of that year. However, that combination may compete in the EI90 Amateur National Championship class. • ERQI must be green or amber at EI90 as per ERQI table above • Athletes with a Red ERQI must obtain a XC Competency Form as per Rule 10.4 before being able to compete at this level or can compete at EI80 • No points awarded
EI90P	<ul style="list-style-type: none"> • Open to all Pony Athletes from the beginning of their 12th year until the end of their 16th year who are Members or Day Members • Underage Athlete combinations must have submitted a Competency Form or be approved by their Regional Co-Ordinator • Open to ponies either registered or on a Day Registration • Ponies must be least 138cms, and 5 years old and over • ERQI must be green or amber at EI90 as per ERQI table above • Athletes with a Red ERQI must obtain a XC Competency Form as per Rule 10.4 before being able to compete at this level or can compete at EI80 • No points awarded
EI80	<ul style="list-style-type: none"> • Open to all Athletes from the beginning of their 12th year who are members or non-members – must be web registered • Open to horses or ponies either registered or web-registration • Ponies must be at least 138cm and 5 years or older • Horses must be at least 148cm and 4 years or older • Dressage test will be EI90 standard as per ERQI table above



Class Type	Criteria
	<ul style="list-style-type: none"> ERQI must be green or amber at EI80 as per ERQI table above Athletes with a Red ERQI must obtain a XC Competency Form as per Rule 10.4 No points awarded and results will be recorded
EI100(T)	<ul style="list-style-type: none"> Open to Athletes from the beginning of their 12th year who are Full or Restricted Members or those on day memberships Underage Athletes - combinations must have submitted a Competency Form or be approved by their Regional Coordinator Horses must be least 148cm, and 4 years old and over Ponies must be least 138cms, and 5 years old and over A pony ridden by an adult must be a minimum of 143cm and 5 years of age No points awarded and no results recorded
EI90(T)	<ul style="list-style-type: none"> Open to Athletes from the beginning of their 12th year who are Full or Restricted Members or those on day memberships Underage Athletes - combinations must have submitted a Competency Form or be approved by their Regional Coordinator Horses must be least 148cm, and 4 years old and over Ponies must be least 138cms, and 5 years old and over A pony ridden by an adult must be a minimum of 143cm and 5 years of age No points awarded and no results recorded
EI80 (T)	<ul style="list-style-type: none"> Open to all Athletes from the beginning of their 12th year who are members or non-members – must be web registered Open to horses or ponies either registered or web-registration Ponies must be at least 138cm and 5 years or older Horses must be at least 148cm and 4 years or older Dressage test will be EI90 standard No points awarded and no results recorded

Note: Under exceptional circumstances, it may be necessary to amalgamate the EI90, EI100 and EI110 classes where all category of Athletes will compete in the same class. Points in an EI110 amalgamated class, will be awarded as per the relevant age group.

National Championships Criteria

Class Type	Criteria
EI120	<ul style="list-style-type: none"> Normal qualification rules will apply
EI115 (Open)	<ul style="list-style-type: none"> Horses with 11 – 50 points will be eligible for this class Normal qualification rules will apply
EI110	<ul style="list-style-type: none"> As per criteria for EI100 and EI90 Horses with up to 38 points will be eligible to enter
EI100 EI90 EI80	<ul style="list-style-type: none"> Three MERs as a combination at Eventing Ireland national events in the past 18 months. The final MER must be achieved at least 5 days before the start of the competition. Qualifications must be at least 3 MERs at the level they wish to enter or 2 MERs at that level and no more than two MERs at a higher level. (ie: 2 x EI90 and 2 x EI100) The MERs are dressage minimum 55% good marks (45 penalties), no more than 16 SJ penalties and clear XC jumping penalties for each event. While all MERs are checked, it will be the responsibility of the Athlete to ensure their MER is correct before making an entry. If MERs are not compliant, prize money and/or placing will be forfeit If you are qualified to enter the higher level, you must run at that level or be prepared to run HC

**Grassroots Championships Criteria**

Class Type	Criteria
EI100 EI90 EI80	<ul style="list-style-type: none">• Two MERs at an Eventing Ireland national event from the past 18 month as a combination. This should be 2 MERs at the class they will be entering• The MERs are dressage minimum 55% good marks (45 penalties), no more than 16 SJ penalties and clear XC jumping penalties for each event.• While all MERs are checked, it will be the responsibility of the Athlete to ensure their MER is correct before making an entry. If MERs are not compliant, prize money and/or placing will be forfeit• Any rider who has not completed two or more EI110 MERs in the previous five years can enter

6.3 Entry Fees

The following entry fees apply

Class	Southern Region	Northern Region
EI120	€165	£130
EI115 Advanced	€145	£110
EI115 Open	€145	£110
EI115	€145	£110
EI110 Open	€115	£88
EI110	€115	£88
EI110J	€115	£88
EI110P	€115	£88
EI110 Amateur	€115	£88
EI105	€105	£85
EI100 Amateur	€100	£80
EI100	€100	£80
EI100J	€100	£80
EI100P	€100	£80
EI90 Amateur	€90	£70
EI90	€90	£70
EI90P	€90	£70
EI100(T)	€75	£65
EI90(T)	€75	£65
EI80 and EI80 (T)	€75	£65

Entry fees to the Eventing Ireland National Championships will be as stated on the Eventing Ireland website.

7 PRIZES

Prizes are awarded as indicated in the scale of prizes to starters, which refers to the number of starters in the Dressage (**excluding HC Athletes who do not count in number of starters when allocating points**).

Scale of prizes to be awarded must be the same for all sections in a class according to the Ratio of Prizes to Starters below. The actual amounts will be published in the individual schedule. If the scale subsequently has to be altered, each Athlete must be informed and given the opportunity to cancel their entry.

No of Starters FOR TABLE 1 ONLY	Prizes
2 - 5	1 st Only
6 - 10	1st - 2nd
11 - 15	1st - 3rd
16 - 20	1st - 4th
21 - 25	1st - 5th
26 - 30	1st - 6th
31 - 35	1st - 7th
36 - 40	1st - 8th
41 - 45	1st - 9th
46 - 50	1st - 10th

7.1 Prize Money

The event organisers are not obliged to pay prize money however, should they wish to pay prize money the following tables apply:

TABLE 1

MINIMUM PRIZE MONEY: SOUTHERN REGION TABLE 1								
Class		EI120	EI115	EI110	EI105	EI100	EI90	EI80
	Entry Fee	€ 165	€ 145	€ 115	€ 105	€ 100	€ 90	€ 75
Place	Starters				May give Prizes In Kind*			
1st	2-5	€165	€145	€115	€105	€100	Rosette	Rosette
2nd	6-10	€140	€120	€100	€90	€85	Rosette	Rosette
3rd	11-15	€135	€115	€95	€85	€80	Rosette	Rosette
4th	16-20	€125	€110	€90	€80	€75	Rosette	Rosette
5th	21-25	€120	€105	€85	€75	€70	Rosette	Rosette
6th	26-30	€120	€105	€85	€75	€70	Rosette	Rosette

MINIMUM PRIZE MONEY: NORTHERN REGION TABLE 1							
Class		EI20	EI115	EI110	EI100	EI90	EI80
	Entry Fee	£130	£110	£88	£85	£70	£65
Place	Starters				May give Prizes In Kind*		
1st	2-5	£130	£110	£88	£85	Rosette	Rosette
2nd	6-10	£125	£105	£85	£75	Rosette	Rosette
3rd	11-15	£120	£100	£80	£73	Rosette	Rosette
4th	16-20	£110	£95	£75	£70	Rosette	Rosette
5th	21-25	£105	£90	£71	£65	Rosette	Rosette
6th	26-30	£105	£90	£71	£65	Rosette	Rosette

TABLE 2

MINIMUM PRIZE MONEY : SOUTHERN REGION TABLE 2											
Class		EI120	EI115	EI110	EI105	EI100			EI90	EI80	
	Entry Fee	€ 165	€ 145	€ 115	€ 105	€ 100			€ 90	€ 75	
Place	Starters				May give Prizes In Kind*						
1st	5-6	€ 165	€ 145	€ 115	€ 105	€ 100					
1st	7-13	€ 300	€ 260	€ 210	€ 190	€ 180	1st	1-5	Rosette	Rosette	
2nd	14-20	€ 150	€ 130	€ 105	€ 95	€ 90	2nd	6-10	Rosette	Rosette	
3rd	21-27	€ 75	€ 65	€ 53	€ 48	€ 45	3rd	11-15	Rosette	Rosette	
4th	27-34	Rosette	Rosette	Rosette	Rosette	Rosette	4th	16-20	Rosette	Rosette	
5th	35-41	Rosette	Rosette	Rosette	Rosette	Rosette	5th	21-25	Rosette	Rosette	
6th	42-48	Rosette	Rosette	Rosette	Rosette	Rosette	6th	26-30	Rosette	Rosette	

Event Organisers must advise if they are paying Prize Money or not and if paying prize money confirm which Prize Money Table they are using before entries open, at the latest before close of entries. This information will be published on the event details on the website.

* **Note:** Prizes in Kind **may be** given in all EI105 and EI100 Classes at the discretion of the Event Organiser and should be at least the equivalent value to the entry fee for First place and thereafter on a declining scale. Rosettes must be given to all Athletes in all classes placed 1st – 6th. Irrespective of the number of starters.

If there is only one Athlete in a class, **no prize money will be awarded.**

Bonus Prizes may be given in ANY CLASS at the discretion of the Event Organiser with the approval of Eventing Ireland.

All Entry Fees for National classes at an International Event, where the Prizes are the same as a National One Day Event, are at the prevailing National Class Entry Fee. Class Entry Fees for a National Class at an International Event where they offer more than the normal prizes, may be higher and are at the discretion of the Organiser with approval of Eventing Ireland.

7.2 Prize Givings

If an official prize giving is required, Athletes or their representative must be punctual and neatly dressed. If the Athlete or representative is not available, they must notify the Event Organiser in advance.

Failure to attend, send a representative, or untidiness will be reported to the Eventing Ireland Steward and may result in disciplinary action and / or loss of prize money.

It is the responsibility of the Athlete or their appointed representative to collect prizes, rosettes or prize money on the day. All prizes or rosettes not collected, or cheques not cashed, from the event organiser within 6 months from the date of the event will be forfeit. Neither Event Organisers nor Head Office are required to post any prizes, rosettes or prize money out to Athletes at any stage.

8 POINTS AWARDED

The number of starters in the Dressage phase will determine the number of points awarded. Points are awarded for 1-4 starters (with some exceptions as noted below) and will be set out as follows:

Completion points are also awarded for a Double Clear Round when that Athlete does not receive points otherwise. **A double clear round is one in which no show-jumping penalties (jumping or time) and no cross-country jumping penalties have been incurred.**

POINTS FOR NATIONAL ONE DAY EVENTS						
PLACE	No of Starters	EI120	EI115	EI110 (21 & OVER runners)	EI110 (20 & UNDER runners)	EI110 6yo & EI110J1*/2*
1 st	1-5	24	10	8	6	3
2 nd	6-10	22	8	7	5	2
3 rd	11-15	20	6	6	4	1
4 th	16-19	18	5	5	3	-
5 th	20-23	16	4	4	2	-
6 th	24-27	14	2	3	-	-
7 th	28-31	12	2	2	-	-
8 th	32-35	10	2	2	-	-
9 th	36-39	8	2	2	-	-
10 th	40+	8	2	2	-	-
Double Clear Round		4	2	2	2	1
Young Rider Classes - Points as for equivalent Senior Class						
Junior Classes – Points awarded to first THREE places only						
Amateur Class – Points awarded for double clear rounds only						

- Points are not awarded for EI80, EI90, EI100, EI105 or EI110 (open) classes
- Day Memberships/Registrations competing EI110 do not receive points even if they have been placed. Points are not awarded retrospectively
- Additional points for the National Championships will be awarded in addition to normal points as follows:

National Championships – All Classes where points are awarded		
Place	Starters	Points in addition to the points above
1 st	2-5	5
2 nd	6-10	4
3 rd	11-15	3

National Championships – All Classes where points are awarded		
Place	Starters	Points in addition to the points above
4 th	16-19	2
5 th	20-23	2
6 th	24-27	1
7 th	28-31	1
8 th	32-35	1
9 th	36-39	1
10 th	40+	1
Double Clear Round		1

POINTS FOR ONE DAY EVENTS: CCI-S – (Short Format International Classes)						
PLACE:	Starters	CCI4*-S	CCI4*W-S	CCI3*-S	CCI2*-S (51 & Over Starters)	CCI2*-S (50 & Under Starters)
1 st	1-5	32	36	16	16	8
2 nd	6-10	29	33	14	14	7
3 rd	11-15	26	30	12	12	6
4 th	16-19	23	27	10	10	5
5 th	20-23	20	24	8	8	4
6 th	24-27	17	21	6	6	3
7 th	28-31	14	18	4	4	2
8 th	32-35	11	15	4	4	2
9 th	36-39	8	12	4	4	2
10 th	40+	5	12	4	4	2
FEI MER obtained		5	6	4	2	2

POINTS FOR THREE DAY EVENTS: CCI-L – (Long Format International Classes)						
PLACE:	Starters	CCI5*-L	CCI4*-L	CCI3*-L	CCI2*-L (51 & Over Starters)	CCI2*-L (50 & Under Starters)
1 st	1-5	180	110	30	20	10
2 nd	6-10	170	100	28	18	9
3 rd	11-15	160	90	26	16	8
4 th	16-19	150	80	24	14	7
5 th	20-23	140	70	22	12	6
6 th	24-27	130	60	20	10	5
7 th	28-31	120	50	16	8	4
8 th	32-35	110	40	13	6	3
9 th	36-39	100	40	13	4	2
10 th	40+	90	40	13	4	2
FEI MER obtained		65	25	5	4	2
CCIOJ2* & CCI0Y3* Points as for Star Rating						

8.1 International Points and MERs Gained Overseas

International Points and MERs gained whilst competing overseas are added to those already accumulated. Participation abroad does not automatically upgrade a horse to the next level unless the points accumulated deem so.

NOTE: It is the responsibility of the Owner/Athlete to notify Eventing Ireland Head Office, in writing, of all International Overseas Event results or competitions for a horse registered with Eventing Ireland so the record of the horse can be correctly updated to reflect the current Points/MER status for the horse.

This must be completed within 5 days of such competition - failure to do so may result in a fine of €100.00.

9 OFFICIALS AND JUDGES

The Organiser appoints all Officials, with the exception of the Eventing Ireland Stewards.

Officials must retire when they reach the age of 80 years of age but may be used in a consultancy capacity.

9.1 Eventing Ireland Technical Advisor, Steward and Assistant Steward

All Eventing Ireland Technical Advisors, Stewards and Assistant Stewards will be appointed by the Stewards Committee. They must be a member of Eventing Ireland and appointed from the list published in Appendix N of the rules. These TA, Stewards and Assistant Stewards will have attended an Eventing Ireland Steward course and must attend a refresher course at least once in every two years. In addition and if required, current FEI TDs may steward at Eventing Ireland events, to the appropriate class level. All stewards should be familiar with the current Eventing Ireland Rule Book and the Stewards Brief.

Eventing Ireland will appoint its own Eventing Ireland Stewards as its official representative at each Official Event. An Assistant Steward must be appointed if there are 125 entries or above.

The TA or Steward will be responsible for carrying out at least two inspections and approvals of the Cross Country Course(s). The first inspection will take place not less than one month before the date of the competition, regardless of the state of the preparation of the course. It is forbidden to alter the course after the second inspection, except with the approval of the TA or Steward. The Steward must also inspect and approve the Show Jumping Course(s) before they are shown to the Athletes. The Stewards are authorised to insist on alterations being made if, in their opinion, these courses are not in all respects within the limits laid down in the rules, or are unsuitable for the classes of horses expected to take part.

The TA or Steward's cross country course inspection of fences, including MIMs or pinned fences, only holds good for the EI competition on the day. This approval does not extend to other affiliated or unaffiliated events.

The Stewards will be present on the day[s] of the Event, and will ensure that they are conducted in accordance with the Rules, to act as the representative of Eventing Ireland and to give what help and guidance may be required. In exceptional circumstances the Eventing Ireland Steward is authorised to reduce the severity of, or to bypass obstacles, or to alter the distances or the speeds demanded.

The Eventing Ireland Steward is responsible on the day for all officials, judges, timekeepers and scorers.

The Eventing Ireland Steward must complete a standard Eventing Ireland report sheet which includes accurate details of any incidents, accidents and infringements of the rules that may require urgent action by Officials of Eventing Ireland. This report must also be received at Eventing Ireland Head Office, within 48 hours of the event.

The Eventing Ireland Steward/Assistant Steward shall have limited powers on the day to reprimand, disqualify (horse/Athlete) or fine members for any misdemeanour (ie. rudeness, continuing on the cross country after elimination, etc) – please refer to Rule 20.6. They may also reprimand any member who fails to comply with a reasonable request of the Eventing Ireland Steward made at an event for the purposes of facilitating the proper running of that event. These members names, the infringements and any action taken will be noted on the Eventing Ireland Watchlist, which may be published within Eventing Ireland from time to time.

9.2 Safety Steward

All Safety Stewards will be appointed from the list of Safety Stewards available from the website.

The Safety Steward works as a member of the event organisation team to assist them achieve the requirements of sensible safety provisions as outlined by nationally recognised health, safety and welfare provisions for outdoor events

The Safety Steward is NOT responsible for the behaviour and conduct of competitors, owners, volunteers, officials, medical or veterinary personnel.

9.3 Dressage Judges

The Organiser will appoint the Dressage Judges for each test as follows:

Class	Judge
EI120	List 1 to 3 or FEI Official International, International or Candidate Judges
EI115	List 1 to 4
EI110	List 1 to 5
EI105	List 1 to 5
EI100	List 1 to 6 or Non-listed with previous DI/BD or FEI judging experience
EI90	List 1 to 6 or Non-listed with previous DI/BD or FEI judging experience
EI80	List 1 to 6 or Non-listed with previous DI/BD or FEI judging experience

It is recommended to have two Judges for the EI120/Advanced Class and Championships, one Judge is sufficient for all other classes. **Judges must be drawn from either the current year's judges list of either Dressage Ireland, British Dressage approved list or the FEI (Dressage and Eventing).** When two judges are used for dressage, one SHOULD be placed at B or E.

9.4 Show Jumping Judges

The Organiser will appoint one Show Jumping Judge per arena, drawn from the SJI approved list of Judges/Deputy Judges or the FEI Event Judges list. It is highly recommended a scribe is present to record each show jumping round.

A Show Jumping Ireland Panel Course Builder or an FEI show jumping course designer must design the course.

9.5 Cross Country Course Designer

The Organiser will appoint the Cross Country Course Designer. The role of the course designer is to set the appropriate test for each level (as per Eventing Ireland Rules and Course Designer Guidelines) and produce a good 'picture'. All Course Designers must be accredited by Eventing Ireland if they are not FEI Course Designers. Course Designers who are not accredited may work under supervision of an accredited Course Designer (Mentor).

The Course Designer is responsible for completing the cross country related reports along with a course map for each track they, or their assistant, design and send to Alison Packman five days prior to the event. A list of approved Course Designers can be found in Appendix O.

The Course Designer should build a fair and safe course for the levels so all have the opportunity to complete. All fences must be compliant with the current FEI Guidelines when using frangible pin or MIM pin technology. Please refer to https://inside.fei.org/sites/default/files/Cross%20country%20Guide%20for%20Officials%2024%20January%202024%20Clean_0.pdf

- Oxers: where MIM Clips and Reverse Pins are available it is recommended that a MIM Clip should be used on the front rail and the Reverse Pin on the back rail. However, both devices are approved.
- Corners: as the MIM skinny post and rail kit is now approved, it is recommended to replace front pinned fences with this system the updated MIM system for open corners using the yellow clips
- Front pins are no longer acceptable on new fences.
- Ground Lines must be used on fences at all levels.
- An additional ground line is not compulsory for fences with a leading edge of 50 cm or less.

9.6 Cross Country Controller

A Cross Country Controller, reporting to the Eventing Ireland Steward, is mandatory at all national events. The Cross Country Controller will be appointed by Event Organiser.

The Cross Country Controller should have assistants to monitor the radios on the event site and must be named in the programme. The Controller will work with the EI Steward to determine the safe intervals between each horse on the course at any one time.

The role of the Cross Country Controller is to:

- a) agree with the Organisers a communication plan for the cross-country test.
- b) confirm that all emergency services (Doctor, 2 ambulances, Veterinary Surgeon, Course Repair, etc) are in place before the start of XC
- c) know exactly where every horse is on the XC track
- d) respond to fence judges with an incident at his/her fence, ask what assistance they need and deploy as required
- e) deploy the required emergency services, ensuring that they understand and are responding
- f) decide if horses must be held on track and if starters must be held due to a blockage on the course
- g) liaise with the Steward and Assistant Steward, and advise if a situation is developing
- h) In consultation with the EI Steward, adjust timetables if necessary.

9.7 Cross Country Fence Judges

The Eventing Ireland Steward must brief and supervise the Fence Judges and Time Keepers prior to the start of Cross Country phase. All Cross Country Fence Judges must be at least 16 years of age.

All Cross Country Fence Judges **should** attend the Stewards Briefing. One fence judge **should** be appointed at each obstacle on the course. Only on approval from the Eventing Ireland Steward may one fence judge take charge of more than one obstacle, providing those fences are all clearly visible to him and he is in a position to maintain adequate control.

Stop Watches should be used at every fence. The time should be recorded by each fence judge for every horse at their fence.

10 ATHLETE INFORMATION

All Athletes will be identified on the EI database as Senior, Young Rider, Amateur, Junior, Pony or Restricted.

Each Athlete will be identified on the EI database as an FEI A, B, C, D or Uncategorised Athlete.

To compete at the higher levels (EI115 and above) it is recommended that Athletes must have achieved the following completions before moving on to the next level.

To compete at	Completions	MER Criteria
EI110	3 x EI100/EI105	<ul style="list-style-type: none"> • Not more than 45 Penalty Points (55% dressage Good Marks) • Not more than 16 SJ penalties • Clear XC jumping penalties • Not more than 75 seconds exceeding the optimum time cross country (ie:30 time penalties) • ERQI 2.0 must be GREEN or AMBER to upgrade as indicated in table in Rule 6.1
EI115	3 x EI110	
EI120	3 x EI115	

A national Minimum Eligibility Requirement (MER) is achieved by completing a competition within minimum parameters of all round performance as follows:

- a) **Dressage:** Not more than 45 Penalty Points (< 55% dressage Good Marks)
- b) **Show Jumping:** Not more than 16 penalties at obstacles
- c) **Cross Country:**
 - A clear round (0 penalties) at obstacles
 - Not more than 75 seconds exceeding the optimum time Cross Country

These qualifications do not have to be as a combination and can be gained with a different horse. Junior and Pony Athletes still need to obtain the Minimum Eligibility Requirement (MER), have a Green ERQI **and** be upgraded by an approved trainer (for EI100) or Level 2 or 3 Eventing Coach to move up to EI110 level (See Rule 5.5 and Rule 5.8 respectively).

The MERs for the National Championship classes may be increased at the discretion of the National Championships Committee.

There might be occasional exceptions for Juniors to move up to EI115 and above and these will need to be agreed with the Junior HSI High Performance Manager. However, in order to be considered for an exception, the following criteria must be met:

1. The combination must be under consideration for selection for the championship in the year. (This means that this dispensation cannot be given after the announcement of the team in the year).
2. The combination must have at least 11 points
3. The combination must hold, or be expected to gain in the immediate future, and in time to compete at the Championships, the FEI qualification requirements to compete at the Championships.
4. The combination must be involved in and committed to the HP programme (ie. have signed an expression of interest) in the year.

Head Office must be notified in writing on an underage Athlete's upgrade. After announcement of the team, this exception will be removed.

10.1 Number of Horses ridden by an Athlete

Athletes, from the beginning of the calendar year in which he reaches the age of 18 (eighteen) and over can ride up to three (3) horses at a one day Event. However, at the discretion of the Organiser, an Athlete may request permission to enter and ride more than three horses, (maximum of 5 at a one day event) and it is the responsibility of the Athlete to present each horse, in the correct place at the correct time.

Athletes from the beginning of the calendar year in which he reaches the age of 17 (seventeen) and younger are not permitted to ride more than 3 horses/ponies at an event in any one day.

10.2 Dangerous Riding

ANY ATHLETE who, at any time during the competition, deliberately or unintentionally by incompetence is exposing himself, his horse or any third party to a higher risk than what is strictly inherent to the nature of the competition will be considered to have acted dangerously and will be penalised according to the severity of the infringement.

Such acts include without limitation any of the following:

- Riding out of control (horse clearly not responding to the Athlete's restraining or driving aids)
- Riding fences too fast or too slow
- Repeatedly standing off fences too far or pushing the horse to the foot of the fence – (firing the horse at the fence)
- Repeatedly being ahead or behind the horse movement when jumping
- Series of dangerous jumps
- Lack of responsiveness from the horse or the Athlete
- Continuing after 3 refusals, a fall or any clear form of elimination
- Endangering the public in any way (eg. jumping out of the roped track)
- Jumping obstacles not part of the course
- Willful obstruction of an overtaking Athlete and/or not following the instructions of the Officials so causing danger to another Athlete
- Jumping from a standstill at a fence with height (ie: 30cm or more)
- **For cases of Pressing a tired Horse, a recorded warning will be issued along with 25 penalties**

Dangerous riding will be sanctioned from 25 penalties, Elimination, Disqualification and a Yellow Card Warning Card (see Rule 20.5) as listed under Rule 20.10.

Three Verbal Warning Cards issued for the same offence in a 12 month period will automatically incur a Yellow Card Warning (see Rule 20.5).

10.3 Elimination Before Cross Country

As a preventive risk management measure, the TA or Steward, at any time throughout the competition has the right and duty to eliminate an Athlete to prevent the Athlete from starting the Cross Country Test, if there is a serious concern regarding their ability to control the Horse in that test. In addition, the Athlete must receive a Recorded Warning.

10.4 Athlete Downgrading

Athletes will be downgraded a level if they persist at a class/grade at which they are struggling or if their ERQI is Insufficient, as per Rule 6.1. As horses can run at up to 3 different levels and HC at EI90 and EI100 level downgrading is easy and can be at the choice of the owner/Athlete.

Compulsory downgrading will be enforced if the same horse/Athlete combination has two consecutive eliminations for horse falls at a fence, Athlete falls at a fence or accumulated refusals in either the show jumping and/or the cross country phase. A total of three (3) cross country eliminations for a horse/Athlete combination within a twelve (12) month rolling period of time will also apply. This applies to both national and international competitions.

The combination will need to attain one clear cross country round at an EI event (excluding training events) at the lower level before upgrading again.

Two consecutive eliminations for falls in the show-jumping phase will also trigger compulsory downgrading and the combination will have to attain a show jumping result at the lower level at an EI event (excluding training events) before upgrading again.

If an Athlete competing at EI110 Level and above is compulsorily downgraded, this may affect their future entries for International competitions at home or abroad as EI will notify the HSI High Performance

Committee and the EI International Administrator of the compulsory downgrading. It will then be up to the HP Committee to take further action should they deem it necessary.

Technical eliminations (ie. error of course) will not trigger compulsory downgrading (see Rule 10.6)

EI80 or EI90 Athletes who have received two consecutive eliminations must attend training with an HSI affiliated trainer or independent trainer holding a recognised training qualification. Before the Athlete is able to compete at that level again, they must supply the Eventing Ireland National Safety Officer with the *EI Cross Country Competency Form*, signed by the trainer. This form can be downloaded from the EI website.

Only on receipt of the EI Cross Country Competency Form, will Head Office adjust the ERQI to allow entry to EI90 or EI80 classes.

All Athletes with two or more consecutive eliminations will be placed on the EI Watchlist which is circulated to event officials. Athletes will remain on the Watchlist for a period of 12 months from the date of the incident.

10.5 After Elimination or Retiring

An Athlete eliminated or retiring for any reason must leave the arena/course at once and has no right to continue. An Athlete must walk his horse off the course, by the shortest safest route, either mounted or dismounted. If an Athlete has fallen, he/she must not remount.

Disobeying this rule will be subject to a summary fine of €30 in addition to any other penalty that may be given.

10.6 Technical Elimination

Technical Elimination applies to **dressage and show jumping phases only** (see Rule 23.26)

An Athlete who has been technically eliminated in the Dressage or Show jumping tests must ask the Eventing Ireland Steward for permission if he / she wishes to take part in the Show jumping or Cross Country tests. Technical Elimination includes jumping the wrong fence, incorrect dress etc.

Such permission **will not be given** in the case of an Athlete who has been eliminated in the Show jumping for two refusals or incurring 20 Jumping Penalties or more, an Athlete fall or a horse fall in any phase.

If permission is granted, the Athlete does not become HC because he/she has been eliminated and the final result will show as Elimination. After elimination in any test, an Athlete who starts their following phase without such permission will be liable to disciplinary action

10.7 Riding-in Competition Areas and Schooling

Except when actually competing, Athletes may not, under penalty of elimination, ride in any Dressage or Show Jumping arenas or near any cross-country obstacle, after these have been prepared for competition. Any subsequent schooling over the Show jumping or Cross-country Course is forbidden.

Horses may be "ridden in" in any saddlery that is permitted for dressage, show jumping or cross-country (ie. cross-country saddlery may be used when 'riding in' for dressage, see Rule 12.2.)

Only horses that are competing at the event may be ridden/lunged on the Event site (see Rule 16.11).

10.8 Ride In / Warm Up

Only the Athlete is permitted to **school or jump** a Horse or Pony at a competition at any time. However, only in the case of Athletes with multiple rides, the Horse/Pony may be **prepared / worked in** for the Cross country phase – (not jumped). At all other times, a suitably dressed and capable Athlete/groom may also hack a Horse/Pony from one place to another, and may work them on the lunge.

10.9 Lungeing

Only horses that are competing at the event may be lunged on the event site. **Lungeing is permitted only with the express permission of the Organiser and / or Landowner. Please ask the Organiser where you can safely lunge your horse BEFORE you start lungeing.** Failure to comply may result in elimination or other disciplinary action at the discretion of the EI Steward.

11 ATHLETE DRESS

11.1 Athlete Dress Code during Competition

Dress	Dressage	Show Jumping	Cross Country
Protective Headgear (Rule 11.2)	Mandatory	Mandatory	Mandatory
Dress Code	See table below	See table below	Sweater or shirt with breeches
Gloves	Compulsory	Permitted	Permitted
Body Protector (Rule 11.5)	Permitted	Permitted	Mandatory
Inflatable Air Jackets (Rule 11.6)	Permitted	Permitted	Permitted
Boots/Gaitors (Rule 11.7)	See table below	See table below	Boots in all tests must be black or black with brown top
Whips (Rule 11.8)	Not permitted	Permitted	Permitted
Spurs (Rule 11.9)	Not Compulsory	Not Compulsory	Not Compulsory
Stop Watches	Not permitted	Permitted	Permitted
Gum Shields	Not permitted	Not permitted	Optional

Dress Code	
Breeches/Jodhpurs	<p>For national events only, Athletes are permitted to wear white or off white, or white/cream with dark seat, or dark coloured breeches/ jodhpurs, which must be of one colour only, during all three phases of competition.</p> <p>White or off white breeches must be worn during international competition as per FEI regulations</p>
Dressage Dress Code	<p>Breeches: (see above)</p> <p>Stock or tie: white or off-white or plain shirt with standup collar (Choker)</p> <p>If a tweed jacket is worn, a coloured or checked stock is permitted</p> <p>Gloves: white, off-white or same colour as coat</p> <p>Riding boots: black or dark colour</p> <p>Tailcoats/jackets: any single colour tailcoat or jacket (approved by the Athlete's NF) will be allowed. Striped or multi-coloured coats or jackets are not permitted. Tasteful and discreet accents, such as a collar of a different hue or modest piping or crystal decorations, are acceptable. Tweed/hacking jackets are permitted for Eventing Ireland events</p>
Show Jumping Dress Code	<p>Athletes are required to wear the uniform or clothing approved by their NF, a jacket, breeches (as noted above), black or brown riding boots. Other dark coloured riding boots may be approved at the discretion of EI steward; riding boots may have one contrasting colour only, around the top, heel and/or toe. Riding boots must have a well-defined heel to avoid slipping through the stirrup.</p> <p>Shirts may have long or short sleeves and must have a white collar; long-sleeved shirts must have white cuffs. A white tie or stock must be worn or plain shirt with standup collar</p> <p>Competition jackets may be any colour and must have outward facing buttons. If the jacket has a collar it must be a lapel collar which may be the same colour as the jacket or a different colour. Jackets without a collar are allowed providing the shirt collar and tie are visible when the jacket is closed. Tweed/hacking jackets are permitted for Eventing Ireland events</p>

Note: The EI Steward may at times, eg: in extreme weather conditions, allow variation of the Dress Rules in consultation with the relevant judges.

To prevent unnecessary injury, hoodies must not be worn, unless tucked in, during warm up or competition.



11.2 Protective Headgear

- Protective headgear is mandatory at all times for all phases at all levels of competition. Protective headgear is defined as “Appropriate Helmet or Headgear that is in compliance with the current applicable international testing standards. It must be properly fastened with a three point retention harness at all times when mounted”.
- Any Athlete or person mounted on a horse violating this provision must immediately be prohibited from further riding until the protective headgear is properly in place.
- Protective headgear must meet one of the following standards

European	<ul style="list-style-type: none"> All PAS 015 (2011) * VG1 01.040 2014-12 * BS EN1384-2023 * <p>*with BSI Kitemark or Inspec IC Mark</p> <p>Protective headgear carrying a CE Mark including products referencing the VG1 performance specification but excluding products referring exclusively to the EN1384:2012 unless it is shown in conjunction with another accepted standard from the present list</p>
American	<ul style="list-style-type: none"> American ASTM F1163: 2004a and subsequent updates American Snell 2016 (Snell combines a standard with subsequent quality testing, therefore no additional quality testing mark is required)
Australian & New Zealand	<ul style="list-style-type: none"> All AS/NZS 3838 (2006 and any subsequent updates)
The CE mark on its own IS NOT ACCEPTABLE	

See **Appendix M** for approved safety standard labels

- Fixed peak hats used for dressage and show jumping are NOT permitted for cross country.
- Skull/jockey hats (with covers) are acceptable for dressage, show jumping and cross country phases.

Hat Type	Accepted Phase	Approved Hat Tag	
Skull Cap (no peak)	DR, SJ, XC	Red	
Fixed Peak	DR & SJ ONLY	Red / White Stripe	
Top Hat	Not Accepted	n/a	

- All protective headgear worn in all EI competitions must show a visible current EI hat tag. Untagged hats must be checked and tagged **before** being used in either a training or competition class
- Wearing untagged or incorrect headgear for a phase could result in a penalty at the discretion of the Eventing Ireland Steward officiating on the day.
- When re-tagging hats, the new tag must be placed on the nearside (leftside), vertical part of the harness and the old EI tag must be removed.
- Athletes are strongly recommended to check their headgear regularly and to replace if damaged, ie: if dropped or following a fall.
- As from 1 January 2026, the following hat standards are no longer be accepted due to the age of hats made to these standards:
 - PAS 015 1998
 - SNELL 2001

Top Hat/Bowler Hat:

- Top Hats or Bowlers are NOT PERMITTED during ANY national competition. Technical Elimination will apply.

11.3 Hair and Jewellery

- When riding in competition, Athletes must ensure that long hair is tied back or placed in a hairnet and is neat. Hair should be no longer than collar length so as not to obstruct the Athlete number.
- All facial piercings, unless they are studs, must be covered with a plaster when going cross country to prevent injury

11.4 Mounted Head Cameras

- All Athletes are permitted to wear a mounted head camera during competition
- The camera must be mounted to the helmet by an easily detachable method (Velcro or elastic) and the integrity of the crash helmet must not be compromised. **Cameras must not be mounted on any other part of the body.**

11.5 Body Protectors

A body protector is mandatory for cross country, cross country schooling and whenever else a body protector is worn.

In order to ensure that Athletes are wearing the most up to date Body Protectors, please note that from 1 January 2026, the Level 3 body protector with the year 2009 (purple label) shown on the label **will no longer be accepted.**

An Exo Body Cage which, if worn, must be declared to the Steward prior to the cross country phase.

Athletes are strongly recommended to check their body protectors on a regular basis and to replace them if damaged.

It is strongly advised that the body protector should not impede flexibility or balance. Body protectors may be randomly checked by Stewards to ensure compliance.

Back protectors are not considered body protectors.

11.6 Inflatable / Air Jackets

It is recommended that Athletes wear air jackets for any jumping phases (for both training and competition). If an Athlete chooses to wear an airbag style body protector, it must be worn over a permitted body protector for the cross country phase. Inflatable/air jackets may be worn for the showjumping and dressage phases without a body protector.

11.7 Riding Boots / Gaiters

Riding boots must be worn in all phases. Boots must be plain dark boots of any conservative colour, and full grain smooth dark leather gaiters of any conservative colour, with matching boots, OR topped boots with breeches.

Juniors under the age of 16 may wear jodhpurs with jodhpur boots OR half chaps/gaiters with jodhpur boots.

11.8 Whips

Phase	Type
Training:	One whip no longer than 120cm, including lash, is allowed when riding on the flat at any time in all eventing competitions. One whip no longer than 75cm and not weighted at the end is allowed while jumping any obstacle.
Dressage	A whip is not allowed entering the space around the arena and during the test
Cross Country & Jumping	A whip no longer than 75cm is allowed during these tests. All whips used in the Cross Country and Jumping Tests must be padded * and made of smooth material. A whip may not have a weighted end, protrusions or raised surface. An adjustable-length whip may not be carried by a mounted Athlete.

Phase	Type
	*Transition period of 1 year (until 1 January 2027). Further clarifications on what type of whip is considered as 'padded' whip will be provided by the FEI in 2026.

Contravention of any of the above rules may result in penalty points being deducted, elimination, and/or a fine and WILL be reported to the Eventing Ireland Disciplinary Committee please refer to rule 21.6.

11.9 Spurs

Spurs are optional for all three phases.

- Spurs capable of wounding a horse are forbidden. Spurs must be of smooth material (metal or plastic). If there is a shank it must not be more than 4cm long and must point only towards the rear. The end of the shank must be blunt to prevent wounding a horse. If the shank is curved, the spurs must be worn only with the shank directed downwards. The overall shank must be measured from the boot to the end of the spur. Metal or plastic spurs with round hard plastic or metal knobs are allowed ("Impulse" spur) and "Dummy spurs" with no shank are allowed. **Anywhere within the grounds of the event, the Athlete when mounted may wear only one spur on each boot.**
- Rowel spurs are allowed in the three phases and when practicing / warming up. If they are used, rowels must be free to rotate and the rowel must be round and smooth (no tines allowed).
- For pony competitions, rowel spurs are not allowed for any phases.

11.10 Earphones

During any warmup or training session Athletes or grooms may wear only one earphone while mounted. Earphones and/or other electronic communication devices (ie: mobile phone) (with the exception of medical devices, eg. Hearing aid) are strictly prohibited in all competition arenas, and such usage is penalised by elimination.

11.11 Mobile Phones

Athletes may not hold or use a mobile phone whilst mounted anywhere on the competition grounds, including the warm up areas. Anyone caught using a mobile phone whilst mounted will incur an automatic €25/£25 fine.

12 SADDLERY AND EQUIPMENT

12.1 Inspection of saddlery

Please refer to the FEI Tack App <https://inside.fei.org/fei/your-role/it-services/mobile-apps/fei-tack-app>

A steward should be appointed to check the saddlery of each horse before it enters the arena or starts a test/phase, **but the Athlete remains responsible for complying with the rules on saddlery.**

Before the Dressage Test, the checking of the bridle must be done with the greatest caution. If the Athlete requests, the bridle may be checked immediately after the test has been completed. However, should the bridle or bit in such a case be found not to be permitted, the Athlete shall be eliminated.

Please refer to APPENDIX C & D: Permitted Bits All Phases And APPENDIX E: Permitted Reins for Lungeing and Permitted Nosebands

12.2 Saddlery for Phases

The following table defines the saddlery that is permitted, not permitted or compulsory at each relevant phase:

Equipment	Riding in Exercise Areas	Lungeing	Dressage	Show Jumping	Cross Country
Bit guard (only smooth sides and those with small soft bristles no longer than 1cm long) & Tongue Guard	√	√	X	√	√



Equipment	Riding in Exercise Areas	Lungeing	Dressage	Show Jumping	Cross Country
Nose Net (1)	√	√	√	√	X
Ear Plugs	X	√	X	X	X
Liquid Titanium or similar type hood	√	√	X	√	X
Ear Covers / Protective Fly Hood (2)	√	√	√	√	√
Body Bandage (spur pad / protection)	√	√	X	√	√
Snaffle Bridle, Micklem multi-bridle (3) (10)	√	√	√	√	√
Double Bridle (4)	√	√	X	√	√
Bitless Bridle	√	√	X	√	X
Pastern Wrap/Sausage boot Correctly positioned and not over tightened	√	√	X	√	√
Nosebands – chain with in or part of a noseband (9)	NOT PERMITTED				
Running and Irish Martingale	√	√	X	√	
Martingale Stoppers	√	√	√	√	√
Bib Martingale	√	√	X	√	√
Side, running reins and chambons	X	√	X	X	X
Neck Strap (6)	√	√	X	√	√
Seat Covers	√	√	X	√	√
Boots, bandages (7)	√	√	X	√	√
Equiboots/hoofboots	√	√	X	X	X
English style saddle	Compulsory	X	Compulsory	Compulsory	Compulsory
Side Saddle	Not Permitted				
Flash, crossed or dropped noseband only with snaffle bridle	Permitted				
Cavesson noseband (5)	Permitted				
Breast plate	Permitted				
Blinkers or	Not Permitted				
Plastic shields that cover the horses's eyes (ie: sunglasses or glasses)	Not Permitted during competition. May be used in stable and grazing areas				
Tongue strap, tying down horses tongue	Not Permitted				
Draw Reins	Not Permitted				
Standing Martingale	Not Permitted				
Any other type of martingale or gadgets (such as bearing, side, running or balancing reins, etc.	Not Permitted				
Sheepskin, or any other attachments, which may affect the horse's field of vision	Not Permitted				
Sheepskin nosebands	√	√	X	√	
Toe stoppers	√	N/A	X	√	

Boots for 4, 5, 6, 7 & 8 Year Old Horses (Specific EI Classes Show Jumping Phase only)

All Young Horse Classes, (4, 5, 6, 7 & 8-Year-Old Horses) must comply with the FEI Young Horse Class Boot Rule – FEI Jumping Annex VIII Tack, Equipment and Artificial Aids.

- (1) Nose nets must be discreet, black, brown or white and cover the nose only, leaving the bit and mouth visible.



- (2) Ear Covers/Protective Fly Hoods are permitted and may also provide noise reduction. However, ear covers/hoods must not cover the horse's eyes and ear plugs are not permitted. They should be discreet in colour and design. They will be systematically checked by Stewards at the end of the test to ensure that nothing prohibited has been added, (ie: special material) or is covered by the fly hoods.
- (3) Compulsory for all EI80, EI90, EI100, EI105 and EI110 classes
- (4) Only permitted for EI115 and above for dressage
- (5) Compulsory with double bridle
- (6) Neck Straps must be secured to the saddle in line with FEI Rules
- (7) All boots must be smooth inside without lumps, protrusions, or a rough surface.
BOOTS FOR SHOW JUMPING:
 - Boots may only have Velcro, Stud or Hook fasteners (straps). Single and Double shell boots are allowed.
 - Any boot that has a pull back, cinch, winch, buckle or click/ratchet fastener (straps) that double back is NOT PERMITTED.
 - The Maximum height of Hind boots is 20cm.
 - Pastern bands and Pastern Rings are allowed for all jumping phases.
- (9) Only one (1) Noseband at any one time, of permitted design and in unmodified manufactured condition, can be worn during any phase of the competition.
- (10) Reins – no additions or attachments are permitted, (ie: sheepskin etc). Reins must not be made of rope material

NOTE: Any piece of tack that impairs the ears to move freely is forbidden

For Dressage, further clarification can be found on FEI Rules Article 539.2

The following is the FEI link for the 2026 FEI Guidelines to the Use of Tack, Equipment and Dress:

<https://inside.fei.org/sites/default/files/Tack%20%20Equipment%20Requirements%20-Eventing%202026%2017%20December%202025.pdf>

13 WEARING OF IRISH TRICOLOUR

13.1 Irish Tricolour Badges

Only members of the Irish Team and nominated individuals competing at the Olympic Games or FEI Senior Championships are entitled to wear the Irish Tricolour Badge on their jackets. In addition, any other individual who finishes 1st, 2nd or 3rd in the final classification at Olympic Games or FEI Senior Championships is subsequently entitled to wear a badge. The entitlement to wear this badge is permanent.

Members of the Young Riders Team and nominated individuals competing in the FEI Young Athlete Championships are entitled to wear the Irish Tricolour Badge with the words Young Athlete embroidered beneath it. They are only entitled to wear the badge until their 23rd birthday.

Members of the Junior Team and nominated individuals competing in the FEI Junior Championships are entitled to wear the Irish Tricolour Badge with the word Junior embroidered beneath it. They are only entitled to wear the badge until their 20th birthday.

Members of the Pony Team and nominated individuals competing in the CCIOP are entitled to wear the Irish Tricolour Badge with the word Pony embroidered beneath it. They are only entitled to wear the badge until their 18th birthday.

13.2 Irish Tricolour on Saddlecloths

The Irish Tricolour will be displayed on the saddlecloths of:

- Members of the Irish Team and individuals, competing at the Olympic Games, Championships and CCIOP 5*/4*, CCIOP, CCIOPJ or CCIOP.
- All Irish Athletes at any other International competition abroad. It is the Athlete's responsibility to obtain a saddlecloth with a Tricolour

14 SPONSORSHIP & ADVERTISING

Each Event Organiser must honour sponsorship agreements entered into by Eventing Ireland for the benefit of the sport of Eventing. Organisers must therefore submit any private sponsorship agreements over €2,000, to Head Office to ensure that there is no conflict of interest.

14.1 Sponsorship of Individuals

An Athlete who competes in an Eventing Ireland or FEI event and receives any form of corporate sponsorship must consult the General Manager of the Society, for referral to Horse Sport Ireland. Such sponsorship shall be deemed to include the riding of horses owned by a company, the use of lorries bearing advertising, payment for advertising in journals and magazines on human or horse clothing or equipment and for the endorsement of commercial products.

14.2 Advertising and Logos: Athletes

Identification of the manufacturer of clothing and equipment may appear only once per clothing item (breeches, gloves, shirt, headgear or on jackets at the height of breast pockets) on a surface area not exceeding 3 sq cms. Identification of sponsors may appear on a surface area not exceeding:

- i. 80 sq cms on each of the two sides of jackets or top garments at the height of breast pockets except during the cross country phase;
- ii. 200 sq cms on one arm only of top garment or 100sq cms on each arm of top garment for the cross country phase;
- iii. For the show jumping and cross-country tests only, the Athlete may bear the logo of his sponsor vertically in the middle of his protective headgear. The logo must not be longer than 25cm or wider than 5cm;
- iv. For the show jumping and cross-country phases only the Athlete may bear the logo of his sponsor on the left leg of his riding breeches. The logo must not be longer than 20cm or wider than 4cm.
- v. 16 sq cms on both sides of shirt collar
- vi. Any logo displayed as mentioned above must be the logo of an EI member.

Grooms may wear a sponsor's logo on their back but it may not exceed 200 sq cms.

No other advertisement or publicity, other than any logo officially authorised by the Board to be worn by all Athletes or the logo of the event sponsor on a number, may be displayed on any Athlete whilst competing. This includes names, letters, numbers, motifs or other insignia which are identifiable with a commercial concern.

14.3 Advertising and Logos: Horses

No advertising or publicity may be displayed on any horse whilst competing, other than an officially approved logo on a saddlecloth or fly fringes/ear covers.

The registered legal owner or joint owner of a horse, who must be a member of Eventing Ireland, may only display logos.

Logos may be displayed at any event, other than one at which logos have been banned by the organiser. The display of the logo is subject to:

- i. The logo being contained within an area of not more than 200 sq cms.
- ii. The logo on a fly fringe/ear covers for the show jumping phase only being contained within an area of not more than 75 sq cm
- iii. The design of the logo having been approved by Eventing Ireland.
- iv. The logo being displayed on the bottom rear corner of a white saddlecloth.

When the Irish Tricolour is displayed on the saddlecloth, the company owner's logo may be displayed above the Tricolour, on the offside only when there is a team sponsor with a logo, and otherwise on both sides.

15 HORSE INFORMATION

Points will be awarded to horses according to their placing and the number of starters in the dressage in all events (One and Three Day) including those confined to Young Riders and Juniors. Points will not be given to any Athlete competing in EI105, EI100, EI90 and EI80 classes.

Horses may compete across a number of classes according to the number of points they hold. The grade of a horse will determine which class they can compete:

Horse points	Classes that can be entered
0 - 10	EI80, EI90, EI100, EI105, EI110
11 – 20	EI105, EI110, EI115
21- 50	EI110 Open, EI115, EI115 Open, EI115 Adv
51 and above	EI110 Open, EI115 Open, EI115 Adv, EI120

Horses with more than 10 points may compete at EI80, EI90, EI100 as Hors Concours (HC). See Rule 3.21.

If a combination can be approved for a 4* CI, having met all FEI and EI MER requirements yet does not have 51 points, they may apply, in writing only, to Alison Packman at Head Office in order to compete in a national EI120 class.

If a combination can be approved for a 3* CI, having met all FEI and EI MER requirements yet do not have 11 points, they may apply, in writing only, to Alison Packman at Head Office in order to compete in a national EI115 class.

15.1 Ponies

A Pony is a small horse whose height at the withers does not exceed 148cms without shoes.

See Rule 29.2 for clarification.

Class Type	Minimum Height	Minimum Age
EI80, EI90P and EI100P	138cm	5 years
EI105	142cm	5 years
EI110 and EI110P	142cm	6 years

15.2 Upgrading of Horses

If a horse is upgraded after the close of entries (see Rule 3.8 Entries/Substitutions) it may compete in the class for which it was originally entered. If a horse, whose entry has been accepted for a class, is subsequently upgraded before the close of entries, it must be transferred to the next higher class. In each case the owner is responsible for notifying Head Office that his horse has been upgraded and for requesting the appropriate transfer. Points will be allotted and horses graded according to a scale published by Eventing Ireland from time to time. See Rule 8 Points.

In addition, only horses with a Green or Amber ERQI will be permitted to upgrade to a new class.

15.3 Downgrading of Horses

Owners must complete the Downgrading of Horses form (in the Downloads section of the website) and send to Head Office if the following criteria is met:

- A horse which has not won any points under Eventing Ireland rules in the current and preceding two seasons/years may be downgraded – all points for that horse will be removed. The horse will be registered as a Horse 0 points or Restricted
- A horse which has been downgraded to Horse 0 points is eligible to compete in classes where points are awarded and will be entitled to the points if it wins
- A horse may only be downgraded once in its lifetime

16 VETERINARY AND HORSE WELFARE

VETERINARY

A Veterinary Surgeon should be present throughout the whole competition, although this is not mandatory while the dressage and show jumping phases are being performed, satisfactory

arrangements must have been made for a Veterinary Surgeon to be available on call. However, a Veterinary Surgeon must be in attendance during the cross country phase. **The Veterinary surgeon should not be a competitor at the event they are officiating.**

Equipment for the treatment of horse casualties, the means for humane destruction and the removal of both injured and dead horses from the course must be available to the Veterinary Surgeon. The event organiser and/or region must have screens available to allow the veterinary surgeon privacy when treating a severely injured animal.

Any treatment carried out onsite by the Veterinary Surgeon must be paid for by the rider/owner at the time of the treatment. Veterinary Surgeons are onsite for emergency treatment only.

16.1 Destruction of severely injured horses

If, in the opinion of the Veterinary Surgeon, a horse is so severely injured that on humane grounds it ought to be destroyed, the following procedure will apply.

If the owner or his authorised agent is present, the Official Veterinary Surgeon will first obtain his agreement. The Owner or his representative may ask for a second opinion. If the Owner or his representative is not available, the Eventing Ireland Steward, acting on the advice of the Official Veterinary Surgeon, may order the destruction of the horse (a second opinion may be asked for). The method of destruction shall be at the absolute discretion of the Veterinary Surgeon.

16.2 Prohibited Substances - Horses

Please refer to *APPENDIX J: Prohibited Substances – Horses*

16.2.1 Authorisation for Emergency Treatment involving medication with Prohibited Substances

The Authorisation for Emergency Treatment Form may be used for retrospective authorisation of medication given before the start of the event providing such medication will not affect the horse's performance by the time it is due to compete. In principle horses should not be treated with a prohibited substance before competition if the substance or its metabolites are likely to be detectable once the horse is under EI rules. However, there may be some circumstances (eg. during transport, mild spasmodic colic) when medication is deemed appropriate on veterinary grounds. On such occasions the treating veterinarian must provide a signed statement describing the substance administered, the dose, route of administration and the reason for treatment. The Event Veterinarian will need to consider carefully whether the time lag between treatment and competition could give the horse an unfair advantage and must advise the EI Steward accordingly.

The EI Steward or EI Head Office reserves the right to cause tests to be carried out at any time. A refusal to submit a horse for the taking of a sample for analysis shall constitute a breach of this rule.

16.3 Lameness - Dressage

If a horse is so lame that in the opinion of the Dressage Judge(s) it ought not to be asked to complete the test, the Judge(s) may, without appeal, eliminate the Athlete from the competition. If there is doubt over the soundness of the horse, the Athlete will be allowed to complete the test and any unevenness of pace will be penalised. In each case the Judge(s) will record and sign a statement on the marking sheet to notify the Eventing Ireland Steward who in the latter case, and in consultation with the Veterinary Surgeon, will decide if the horse shall be permitted to continue in the competition.

16.4 Blood on Horses

Blood on Horses must be reviewed case by case by the Steward, and this applies to either riding in or during competition. Not all cases of blood will lead to elimination or a Yellow Warning Card. The cases indicating Abuse of Horse will be dealt with according to Rule 16.8

Dressage Test: If the dressage judge suspects bleeding on the Horse during the test, the judge may stop the Horse to check. If the Horse shows fresh blood, it will be eliminated. The elimination is final. If the Judge through examination clarifies that the Horse has no fresh blood, the Horse may resume and finish its test.

Cross Country Test: For the Cross Country Test, all Athlete-induced (spurs, bit and whip) blood on the Horse, must be reviewed case by case by the Steward. If the horse shows fresh blood, Officials may authorise the rinsing or wiping of the mouth and if there is no further evidence of bleeding, the Athlete is allowed to continue. Cases of significant blood will result in Elimination.

Jumping Test: Any blood on the horse caused by tack or equipment or any Athlete induced blood will result in an Eventing Warning

Recorded Warning

- a) In other cases of blood on the Horse (for example where a Horse appears to have bitten its tongue or lip or in cases where a Horse is bleeding from the nose), the Officials may authorise the rinsing or wiping of the blood and allow the Athlete/Horse combination to continue the Competition, provided that the horse is deemed fit to compete in accordance with the paragraph below. The Athlete will not receive an Eventing Recorded Warning if this applies.
- b) In all cases of blood on the Horse, the Horse may only be permitted to continue in a Competition or participate in any subsequent Competition(s) at the Event if the Steward, in consultation with the Vet, has deemed the Horse to be fit to compete.

For all minor cases of blood induced by the Athlete in the mouth or related to spurs an Eventing Recorded Warning will be issued by the Steward after providing the Athlete the opportunity to have a hearing.

16.5 Unfitness of horses

At any time during the competition, a horse which in their opinion is unfit to continue for any reason may be eliminated by the Eventing Ireland Steward. Any such decision may be taken on the advice of the Show Jumping Judge, the cross country controller the Veterinary Surgeon, or the Eventing Ireland Technical Adviser. Athletes are warned that competing a horse in such a condition can amount to a breach of the Rule 16.

16.6 Horse Fall

A horse is considered to have fallen when at the same time both its shoulder and quarters have touched either the ground or the obstacle and the ground or when it is trapped in a fence in such a way that it is unable to proceed without assistance or is liable to injure itself.

A horse which falls at any phase during competition or during the warm-up for any phase, whether or not at a practice obstacle, may not continue unless passed to do so by the Veterinary Surgeon/erinary Officer.

Following a horse fall on the cross country, a systematic interview/discussion must take place between the Athlete and the EI Steward/TA.

The owner of a horse, which has two falls within a calendar year, may receive an advisory letter from the Stewards Committee. Further action may be taken if a horse has a third fall within a calendar year.

HORSE WELFARE

16.7 Rapping

It is forbidden, under penalty of elimination, to rap a horse in any way before, during or after a competition or at any time during an event, and no part of any obstacle may ever be held by anyone whilst a horse is jumping it.

16.8 Abuse of Horse

Welfare of the Horse is priority.

Competitors or anyone involved in handling of a horse, must never ill-treat or abuse a Horse in any way whatsoever. Any instances involving a non-member ie. a groom, will result in sanctions being imposed on

the competitor. Any occurrences of Abuse of the Horse will automatically incur a Disciplinary Action as listed in Rule 20

Any act or series of actions, which, in the opinion of the Eventing Ireland Steward, constitutes abuse of a horse, shall be in breach of these rules. Such acts will include:

- Rapping
- Riding at excessive speed
- Riding an exhausted, lame or injured horse is always excessive
- Excessive pressing of a tired horse
- Excessive use of whip (see Rule 16.9)
- Any spurs capable of wounding a horse, or resulting in injury, are forbidden.
- Use of spurs to reprimand a horse is always excessive
- Horses bleeding on the flank(s) or back indicating excessive use of the whip and/or spurs

If not directly witnessed by an official, the incident must be reported as soon as possible to the Secretary of the event. The EI Steward will decide if there is a case to be answered.

16.9 Use of Whip

Excessive and/or misuse of the whip maybe considered abuse of Horse and will be reviewed case by case according to, but not limited to, the following principles.

- The whip cannot be used to vent an Athlete's temper. Such use is always excessive
- The whip is not to be used after elimination or after a horse has jumped the last fence on a course
- The whip is never to be used overhand, (eg. a whip in the right hand being used on the left flank).
- The use of a whip on a horse's head etc, is always excessive use.
- A horse should never be hit more than two times for any one incident anywhere on the event grounds (including warm up and to/from horse box to competition area).
- Multiple excessive uses of a whip between fences
- If a horse's skin is broken or has visible marks the use of whip shall be deemed to be excessive

Any Athlete identified as misusing or for excessive use of the whip will be eliminated at the discretion of the Eventing Ireland Steward. Please also refer to Rule 11.8

16.10 Warnings and Penalties

Any act or series of actions that in the opinion of the Steward or an Official can be defined as abuse of horse will be dealt with one or more of the following provisions:

- a) Recorded Warning
- b) Yellow Warning Card
- c) Elimination
- d) Fine
- e) Disqualification

16.11 Participation of Horses

Only horses competing at the event, as published on the Eventing Ireland website, are permitted on the event site. They must be registered with Eventing Ireland (see Rule 2 Registration).

All horses must be sound and free from infection or contagious disease; "tubed" horses (horses that have had a tracheotomy) may not compete. Horses are not eligible to compete at any time when any limbs or parts of a limb has been temporarily or permanently desensitised by any means.

A horse is not eligible to compete if the horse's sensory hairs have been clipped and/or shaven or in any other way removed unless sensory hairs have been removed by a Veterinary Surgeon to prevent pain or discomfort for the Horse. Areas of hair that must be clipped, shaven or removed to allow veterinary treatment are exempt from this rule.

In One Day Events, horses must be at least 148cm without shoes, (a pony ridden by an appropriately sized adult must be a minimum of 143cm and 5 years of age). Horses must be registered as a Horse and may only compete in an event from the beginning of the calendar year in which the horse reaches the age of four, however, four year olds may compete in EI100, EI90 and EI80 Classes only.

16.12 Unattended Horses

It is prohibited to leave any horse unattended when tied in an unconfined area under penalty of ELIMINATION and/or FINE. Temporary enclosures are not permitted, save with express permission of the organiser. A break device (such as fine twine) must be used when tying a horse to a vehicle. It is an offence to tie a horse/pony directly to a vehicle.

16.13 The FEI Code of Conduct for the Welfare of the Horse

The FEI requires all those involved in international equestrian sport to adhere to the FEI Code of Conduct and to acknowledge and accept that at all times the welfare of the horse must be paramount. Welfare of the horse must never be subordinated to competitive or commercial influences. The following points must be particularly adhered to at both International and National Eventing Ireland events:

1. General Welfare

a. Good Horse management

Stabling and feeding must be compatible with the best horse management practices. Clean and good quality hay, feed and water must always be available.

b. Training methods

Horses must only undergo training that matches their physical capabilities and level of maturity for their respective disciplines. They must not be subjected to methods which are abusive or cause fear.

c. Farriery and tack

Foot care and shoeing must be of a high standard. Tack must be designed and fitted to avoid the risk of pain or injury.

d. Transport

During transportation, horses must be fully protected against injuries and other health risks. Vehicles must be safe, well ventilated, maintained to a high standard, disinfected regularly and driven by competent personnel. Competent handlers must always be available to manage the horses.

e. Transit

All journeys must be planned carefully, and horses allowed regular rest periods with access to food and water in line with current FEI guidelines.

2. Fitness to compete:

a. Fitness and competence

Participation in competition must be restricted to fit horses and Athletes of proven competence. Horses must be allowed suitable rest periods between training and competitions; additionally rest periods should be allowed following travelling.

b. Health status

No horse deemed unfit to compete may compete or continue to compete; veterinary advice must be sought whenever there is any doubt.

c. Doping and Medication

Any action or intent of doping and illicit use of medication constitutes a serious welfare issue and will not be tolerated. After any veterinary treatment, sufficient time must be allowed for full recovery before competition.

d. Surgical procedures

Any surgical procedures that threaten a competing horse's welfare or the safety of other horses and/or Athletes must not be allowed.

e. Pregnant/recently foaled mares

Mares must not compete after their fourth month of pregnancy or with foal at foot.

f. Misuse of aids

Abuse of a horse using natural riding aids or artificial aids (eg. whips, spurs, etc.) will not be tolerated.

3. Events must not prejudice Horse welfare:

a. Competition areas

Horses must be trained and compete on suitable and safe surfaces. All obstacles and competition conditions must be designed with the safety of the horse in mind.

b. Ground surfaces

All ground surfaces on which horses walk, train or compete must be designed and maintained to reduce factors that could lead to injuries.

c. Extreme weather

Competitions must not take place in extreme weather conditions that may compromise welfare or safety of the horse. Provision must be made for cooling conditions and equipment for horses after competing.

d. Stabling at Events

Stables must be safe, hygienic, comfortable, well ventilated and of sufficient size for the type and disposition of the horse. Washing-down areas and water must always be available.

4. Humane treatment of Horses:

a. Veterinary treatment

Veterinary expertise must always be available at an event. If a horse is injured or exhausted during a competition, the Athlete must stop competing and a veterinary evaluation must be performed.

b. Referral centres

Wherever necessary, the horse should be collected by ambulance and transported to the nearest relevant treatment centre for further assessment and therapy. Injured horses must be given full supportive treatment before being transported.

c. Competition injuries

The incidence of injuries sustained in competition should be monitored. Ground surface conditions, frequency of competitions and any other risk factors should be examined carefully to indicate ways to minimise injuries.

d. Euthanasia

If injuries are sufficiently severe a horse may need to be euthanized by a veterinarian as soon as possible on humane grounds, with the sole aim of minimising suffering.

e. Retirement

Horses must be treated sympathetically and humanely when they retire from competition

5. Education:

The FEI urges all those involved in equestrian sport to attain the highest possible levels of education in areas of expertise relevant to the care and management of the competition horse.

This Code of Conduct for the Welfare of the Horse may be modified from time to time and the views of all are welcomed. Particular attention will be paid to new research findings and the FEI encourages further funding and support for welfare studies.

17 PASSPORTS AND VACCINATIONS

17.1 Passports

Passports MUST accompany ALL horse / ponies to ALL competitions. Spot passport checks and microchipping checks will be carried out at events. All discrepancies must be certified by the Veterinary Surgeon on the day and notified to the Steward.

Owners / Athletes not in possession of passports or those with incorrect passports will be **TECHNICALLY ELIMINATED** and will not be able to compete.

Horses/ponies competing on a **Day Registration** must have a correct passport, which must accompany the horse to an event.

Note: Should a passport not accompany any horse/pony and the horse/pony is selected for an Anti-Doping Test under the rules on Anti-Doping, see APPENDIX J: Prohibited Substances – Horses, will be technically eliminated and the Athlete fined €200.00. **It is the Athlete who will be held responsible and fined in this instance.**

All passport applications or amendments must be sent to the issuing body of the passport.

All horses newly registered with Eventing Ireland and the FEI must be identifiable with a microchip, compatible with ISO 11784 and ISO 11785. All microchip information must also be entered into the horse's passport.

Since 1 January 2005, all horses competing in EI/FEI Competitions, require an influenza vaccination as per the following Rules:

17.2 Vaccinations : National Competitions

(NOTE: Vaccinations at International Competitions are different, please see Rule 29.3)

Loose vaccination certificates are NOT acceptable – all vaccinations must be recorded and stamped in the Passport or the Athlete will be subject to a €50 fine.

No Horse may take part in an EI National Event (which includes entering competition stables) unless it has a current vaccination against equine influenza which complies with the following conditions:

- **Prior to 2026** an initial Primary Course of two vaccinations (V1 and V2) must be given with the second vaccination being administered within 21 - 92 days of the first vaccination.
- The first booster (V3) must be administered within 7 calendar months of the date of the second vaccination (V2) of the primary course.

No Horse may take part in an EI National Event (which includes entering competition stables) unless it has a current vaccination against equine influenza which complies with the following conditions:

The content is not new but just put in a table to make it easier to understand:

Vaccination Course start date	Prior to 2005	Prior to January 2024	Post 1st January 2024
V1 (Initial Primary)			
V2 (2nd Primary) *	21 – 92 days	21 – 92 days	21 – 60 days

V3 (1st Booster)	No requirement	Within 7 Months	Within 6 Months & 21 days of V2
Subsequent Booster	Not more than 1 Year (12 months)		
<p>Horses competing in events must not have received a vaccination within 7 days prior to arrival at the event. The horse can compete on the 8th day.</p> <p>*Horses may compete after they have received both primary vaccinations.</p>			

*** Please note:**

- All proprietary Influenza vaccines are accepted, provided the route of administration complies with the manufacturer's instructions (i.e. intramuscular injection or intranasal).

Notwithstanding the above, at the discretion of the Event Veterinary Officer, in consultation with the EI Steward, in cases where there are other historical discrepancies in a Horse's vaccination record, that Horse may nonetheless take part in an Event on such conditions as the Veterinary Officer considers appropriate, but the circumstances must be noted on the certificate. The Horse must restart its vaccination course before it is eligible to compete at another EI event.

Please note:

- Horses that have received the Primary course prior to 1 January 2005 are not required to fulfil the requirements for the first booster (V3), providing there has not been an interval of more than 12 months between each of their subsequent annual booster vaccinations.
- All proprietary Influenza vaccines are accepted, provided the route of administration complies with the manufacturer's instructions (ie. intramuscular injection or intranasal).
- The Record of Vaccination(s) in the Horse's passport must be completed by the appropriate veterinary surgeon in which the record of injection(s) is completed, signed and stamped line by line.
- The name and batch number of the vaccine and the date of administration must be recorded on the correct vaccination page.
- Vaccination must be administered by a veterinarian who must sign and stamp the passport against the relevant vaccination entry.
- Errors in recording vaccination details must be corrected by marking a single line through the incorrect information and re writing all the details for that vaccination on a new line. The veterinarian marking through the incorrect information must place their initials next to the deletion. The use of correction fluid is prohibited.
- When a new or duplicate passport is issued, the Horse's veterinarian can use the following statement to summarise a long equine influenza history "the vaccination history of this horse is correct to date in accordance with veterinary regulations. Last vaccination on 00/00/00 date ".

Notwithstanding the above, at the discretion of the Event Veterinary Officer, in consultation with the Eventing Ireland Steward, in cases where there are other historical discrepancies in a Horse's vaccination record, that Horse may nonetheless take part in an Event on such conditions as the Veterinary Officer considers appropriate, but the circumstances must be noted on the certificate. The Horse must be re-vaccinated so as to comply with this Rule and the certificate duly completed before it becomes eligible to compete in its next event.

Any companion horse/pony attending an event should also be fully vaccinated and have a passport.

VACCINATIONS – INTERNATIONAL COMPETITIONS

Please see Rule 29.3

18 MEDICAL

Definitions:

In the Republic of Ireland (ROI), a Medical Officer is a Doctor who is currently registered in the appropriate division of the Medical Council of Ireland, with up to date pre-hospital trauma training, which allows the doctor act as a Medical Officer at Horse Trials. **The treating doctor cannot be a competitor at the event they are officiating.**

In Northern Ireland (NI), a Medical Officer is a Doctor who is registered in the appropriate division of the General Medical Council (GMC) of the United Kingdom, with up to date pre-hospital trauma training, which allows the doctor act as a Medical Officer at Horse Trials.

In the Republic of Ireland "Paramedic" means a person who is registered with the Pre-Hospital Emergency Care Council (PHECC) on the Paramedic division of the register, holds a current Paramedic license and is acting on behalf of an organisation (paid or voluntary) that is approved by PHECC to implement Clinical Practice Guidelines. The Paramedic must not be the driver of the emergency vehicle.

In Northern Ireland "Paramedic" means a person who is registered with the Health Professions Council (HPC) on the Paramedic register and who holds a current Paramedic license.

Ambulance:

In the Republic of Ireland ambulance services shall be from an organisation (paid or voluntary) that is approved by PHECC to implement the Clinical Practice Guidelines at EMT (Emergency Medical Technician) level or above.

In Northern Ireland ambulance providers must be registered with the Care Quality Commission.

Before any event can start, there must be in attendance, either a **Medical Officer or Paramedic (in ROI) or a Paramedic (in NI)**. *Please note the Paramedic in the ROI must be currently employed as a Paramedic, retired Paramedics are not acceptable.*

Any phase incorporating jumping shall not begin until there is in attendance a **Medical Officer or Paramedic (in ROI) or Paramedic (in NI)** and at least one Ambulance and crew. The cross-country phase must have two ambulances in attendance, one of which must be present on site whilst the competition is in progress. One ambulance must be 4Wheel Drive and capable of accessing all areas of the Event course.

In case a seriously injured patient needs road transport to hospital - the paramedic must NOT BE THE DRIVER. If the doctor on duty must travel in the ambulance with the patient, the event cannot continue without medical cover

The Eventing Ireland Steward will ensure that before competition begins the following are available for the **Medical Officer and/or Paramedic** and the Steward will have consulted with Medical Officer and/or Paramedic with respect of same:

- i. Access to a four wheel drive vehicle
- ii. Ambulances as outlined above for the various phases
- iii. All areas of competition must be readily accessible for medical support vehicles and ambulances.
- iv. At least one ambulance must remain on site should the road ambulance be transporting a patient to hospital.
- v. All falls and injuries incurred during the competition either directly or indirectly must be reported to the **Medical Officer and/or Paramedic** on duty who will have the absolute discretion as to whether that Athlete is fit to continue on that day. The **Medical Officer and/or Paramedic** on the day shall decide the length of time on which an Athlete should be suspended from competition. These details must be recorded in the Medical Book.

Athletes returning after injury should have their medical condition cleared through the Medical Officer before they ride at a competition and the Eventing Ireland medical book must be completed by the **Medical Officer and/or Paramedic**, unless it has already been done by the Athlete's own Doctor or a Consultant. Please also see Appendix Q Medical Cover at Events

18.1 Athlete Medical Information

To ensure that vital information is available to first aid or medical personnel in case of emergency, Athletes must comply with the following:

- a. Athletes must provide an "In Case of Emergency" (ICE) contact number that is active for the day of competition to the Event Organiser.
- b. Athletes under the age of 18 on the date of competition must have their medical information (ICE) signed by a parent or guardian.
- c. Declaration of serious medical condition

Athletes with medical conditions that may be relevant in the case of a medical emergency are responsible, at every event when riding, for wearing a medical data carrier* from a system provider able to communicate information if they so wish.

** Medical data carrier (also called "medical identification tag"): small emblem or tag worn on a bracelet, neck chain, or on the clothing, intended to alert paramedics/physicians/first responders that the wearer has an important medical condition.*

*Conditions that are relevant include **serious head/spinal injury, concussion having occurred during the last 3 months, chronic health problems such as epilepsy, diabetes, Anticoagulation (blood thinners) serious allergies.** If in doubt, the Athlete should discuss this with his own treating physician.*

18.2 Athlete Fall – Definition and Procedure

An Athlete is considered to have fallen when he is involuntary separated from his horse in such a way as to necessitate remounting. An Athlete fall during any competition phase is automatic elimination. For safety purposes all falls during competition will be recorded and will impact the ERQI rating.

Athletes **MUST** report to the Doctor (in ROI) or Paramedic (in NI) as soon as possible after a fall. It is the responsibility of the Athlete to ensure compliance with this requirement. Athletes should not remount their horse until the examination has been completed.

Athletes failing to report to the Doctor on site (in ROI) or Paramedic (in NI), having had a fall of any description anywhere on the site of the event, will be fined €50.00. They may also receive a verbal warning or Yellow Warning Card (see Rule 20.5). All Athlete falls are recorded on the Eventing Ireland Watchlist for a period of twelve months from the date of the fall.

Note: If any Athlete has a subsequent horse(s) to ride, he/she must get clearance from the event medical officer before proceeding in the competition.

If any Athlete, either during or after the competition, or official training (either HSI High Performance or otherwise), has been hospitalised for any reason, stood down or deemed unfit to ride by Eventing Ireland and/or another authority, either at home or abroad (ie: Horse Racing Ireland, British Eventing) that Athlete **must not** compete until they have been cleared by their General Practitioner to do so.

Before being allowed to compete again, any Athlete who was sent to hospital regardless of whether the accident has been on a horse or not, for any reason, must send a discharge letter from the hospital and a letter from the Athlete's own GP confirming they are fit to ride to Eventing Ireland's Honorary Medical Officer, Dr Mary Flannery (drmaryoflynnflannery@gmail.com). Failure to adhere to this rule will incur a €250.00 fine and a suspension for a further 4 weeks from the date they are cleared to ride again.

Please also refer to Concussion Rule 18.3

18.3 Concussion

- a) Athletes sustaining concussion will be given printed information on head injuries by the Medical Officer and/or Paramedic on site and will not be permitted to ride again on day of diagnosis. It is recommended Athletes contact their own General Practitioner as soon as possible following a diagnosis of concussion.
- b) Suspension from riding of any kind at an Eventing Ireland Competition, or similar eventing organisation or affiliate at a national or international event, at home or overseas, for twenty one days is mandatory, but can be amended to ten days if he/she is asymptomatic and certified fit by their own Medical Practitioner. This suspension can be reduced to seven days if the Athlete has previously had psychometric testing and re-attains that level
- c) All suspensions are recorded by the EI Head Office and repeated episodes of concussion must be reviewed by a Consultant Neurologist
- d) Any Athlete who has been rendered unconscious for a significant length of time as determined by the Medical Officer and/or Paramedic and has amnesia will be sent to the hospital for evaluation and will be stood down for a mandatory period of twenty one days including the day of the accident.

If an Athlete has two recorded occurrences of concussion within a five year period (either in or out of competition), he/she will be required by Eventing Ireland to have a neurological consultation arranged by his/her own GP before they will be allowed to compete either at national or international events.

Eventing Ireland reserves the right to seek a neurological evaluation of report where the Chief Medical Officer deems it necessary.

In the case of concussion an Athlete will under no circumstances be allowed to ride horses at any Eventing Ireland competition (whether training or otherwise) before the date entered on their medical clearance.

18.4 Medical Fitness

If there is any doubt with regard to fitness to compete of an Athlete at any time during the competition, the Steward, in consultation with the Official Medical Officer, may, at his own discretion, eliminate the Athlete and decide also about his eligibility to take part in any other phase at that event.

Any such elimination must be reported to the EI Head Office through the Steward's report.

18.5 Prohibited Substances - Athletes

Refer to APPENDIX K : Prohibited Substances - Athletes

It is forbidden for an Athlete to compete while under the influence of any stimulating, calming or other drug or substance as detailed in the HSI/FEI rules.

HSI and member bodies are signatories to the World Anti-Doping Agency Code.

It is the Athlete's responsibility that if he/she competes at an FEI Event or at an Eventing Ireland competition to ensure that he/she is not taking any prohibited substance. If an Athlete is receiving treatment by a Doctor with medication which includes a prohibited substance, the Athlete may be able to continue competing after the provision of a **Therapeutic Use Exemption Certificate**.

Lists of prohibited substances are regularly updated and are available from the Irish Sports Council www.irishsportsCouncil.ie



TREO EILE

Retraining Ireland's Racehorses



€50,000

SUPPORTS FOR THOROUGHBREDS IN
EVENTING IN 2026, INCLUDING

€5000

THOROUGHBRED EVENTING
LEAGUE PRIZE

www.treoeile.com

087 782 1199

Photo: Tony Walker Photography

19 SCORING (One Day Events)

19.1 Scoring – Dressage (National Tests)

The good marks from 0 to 10, including half marks, awarded by each judge to an Athlete for each numbered movement of the dressage test together with the collective marks are added together deducting any error of course or test.

For each judge the percentage of maximum possible good marks obtainable is then calculated. The percentage is obtained by dividing the total good marks of the judge (minus any error of course or test) by the maximum possible good marks obtainable, and then multiplying by 100 and rounding the result to two decimal digits. The value is shown as the individual mark for that judge.

Average percentage for the Athlete is obtained by adding together the percentage for each judge, and dividing by the number of judges, always rounding the result to two decimal digits.

In order to convert average percentage into penalty points, this must be subtracted from 100 with the resulting figure being rounded to one decimal digit. The result is the score in penalty points for the test.

The Chief Scorer should ensure that the judges marking sheets are available for Athletes as soon as possible after the dressage penalties for each class have been calculated and published. In the case of equality of marks, a note should be made by the scorers of the judges **TOTAL GOOD MARKS** before the marking sheets are handed out.

19.2 Scoring – Dressage (FEI Tests)

The good marks from 0 to 10 awarded by each judge to an Athlete for each numbered movement of the dressage test together with the harmony mark are added together deducting any error of course of test.

For each judge the percentage of maximum possible good marks obtainable is then calculated. (Percentage is obtained dividing total good marks and errors of the judge by maximum possible good marks obtainable and then multiplying by 100 and rounding the result to two decimal digits. This value is shown as the individual mark for that judge. (Rounding the result to 2 decimals includes any score of x.xx5 and above is round up and any score less than x.xx5 is rounded down).

Average percentage is calculated on the average good marks and errors by adding together the total good marks for each judge and dividing by the number of judges. The Athlete's percentage will always be rounded to two decimal digits.

In order to convert average percentage into penalty points, this must be subtracted from 100 with the resulting figure being rounded to one decimal digit. The result is the score in penalty points for the test (Rounding the result to one decimal implies that any score of x.x5 and above is rounded up and any score less than x.x5 is rounded down).

19.3 Scoring – Show Jumping

Four (4) penalties are incurred for each knock-down. For EI110 classes and above, time penalties of 0.4 will be given for every second over the optimum time. Both penalties are added together to give the Athlete a total show jumping result. There are no time penalties for EI80, EI90, EI100 or EI105 classes. Please refer to Rule 22.7 Show Jumping Penalties.

19.4 Scoring – Cross Country

The penalties incurred for faults at the obstacles and for exceeding the Optimum Time are added together to give the Athlete a total penalty score for cross country.

Time penalties of 0.4 will be added for every commenced second in excess of 30 seconds under the optimum time (ie: travelling too fast)

Time Penalties are 0.4 for every second over the optimum time. Please refer to Rule 23.25 Cross Country Penalties.

19.5 Equality of Marks

The winner is the Athlete with the lowest total of penalty points from the three tests.

In the event of Equality of Marks between two or more Athletes, the classification is decided by:

1. The best cross-country score including penalties for faults at obstacles, time penalties and any other penalty that he may have incurred on the cross country test.
2. If there is still equality, the classification is decided in favour of the Athlete with the highest positive Dressage points
3. If there is still equality, the classification is decided in favour of the Athlete whose cross country time was closest to the optimum time.
4. If there is still equality, the Athlete with the best jumping score including penalties at obstacles and time penalties.
5. If there is still equality, the Athlete with the fastest time in the jumping test.
6. If there is still equality, the classification will be decided in favour of the Athlete with the best total of collective marks in the dressage test.
7. If there is still equality the tie will remain in the final classification

19.6 Publication of Results

Individual scores may be displayed on the public scoreboard (at the discretion of the organiser) and online as soon as possible after an Athlete has completed any phase of the competition.

The final result is the combined total of the good dressage marks, total show jumping marks and total cross country marks.

NOTE: All results posted during the running of the event are PROVISIONAL and should be treated as such.

The final results are those posted on the public scoreboard (at discretion of the organiser) and online at the end of the event. The placing of the prize winners should not be officially listed for that section until all the scores for that section are complete. When the placings are posted on the scoreboard the time must be noted and this is the official time of posting. See Rule 20.1 in respect of Objections.

20 OBJECTIONS AND DISCIPLINARY PROCEDURES

20.1 Objections

All queries relating to the event must be made through the Event Secretary's Office for investigation by the Eventing Ireland Steward. Only the Eventing Ireland Steward may approach the judge, timekeeper, scorer or official concerned in respect of any query.

Following investigation by the Steward, if the query is unresolved, the owner, authorised agent or Athlete may lodge a formal objection. Objections must be made in writing on the Official EI Objections Form (available from the Secretary of the Event) and handed directly to the secretary of the event, accompanied by a deposit of €50. Any objection must be made not later than half an hour after the occurrence which gave rise to the objection or, where the score is concerned, after the publication of the final scores, and not later than one hour before the start of the class in the case of an objection to the course, or to the qualifications of any Athlete. **There will be no queries after 8pm on the day of the event. If there has been a genuine mistake/error, the results may be amended up to noon on the Monday following the event.**

The Eventing Ireland Steward, whose decision is final, will consider all objections. The deposit is forfeit unless the objection is upheld or the Eventing Ireland Steward decides that there were good and reasonable grounds for the objection.

To avoid any misunderstanding, only official photographs or video recordings can be used as evidence in the event of an objection.

20.2 Breach of FEI / HSI / IOC Rules

Any suspension from taking part in International Events, incurred by an Athlete for a breach of FEI/HSI/IOC Rules, shall apply equally to all official national events.

20.3 Reprimand/Disgraceful Conduct

Any member of Eventing Ireland or any person participating in anyway at a National Event or an FEI Event, or in any meeting, gathering or matter directly relating to Eventing who conducts himself or herself in a disgraceful manner, behaves with incivility or contempt towards an official, or behaves in a manner which brings the name of Eventing Ireland into disrepute shall be guilty of a breach of these rules.

20.4 Fines

The penalty fines for any breaches of rules will be:

First offence:	Reprimand/Verbal Warning, 25 penalties to elimination, a Yellow Card Warning and/or fine up to €100
Second offence:	Reprimand/Verbal Warning, 25 penalties to elimination, a Yellow Card Warning and up to a €200 fine if no previous fine, or up to a €100 fine if previously fined, with right to appeal to Disciplinary Committee. Mandatory referral to the Disciplinary Committee if a second offence occurs within twelve months.
Incorrect Passport	Technical Elimination and subject to a fine of €50.00. Second Offence incurs a fine of €100. Fine will be increased to €200.00 for failure to produce passport for Anti-Doping
Continuation	Discretionary fine of €25.00

Any penalties or restrictions applied to Eventing Ireland members by the Eventing Authorities of all other countries shall also apply in the jurisdiction of Eventing Ireland.

An appeal may be made to the Disciplinary Committee against a fine or disqualification, otherwise any decision of the Eventing Ireland Steward is final and there is no appeal. An appeal must be made to the Disciplinary Committee within 7 days of the end of the event. Any fine imposed shall be applicable immediately. The Disciplinary Committee may refund any fine in the event of an appeal being successful.

Note: All fines imposed by Eventing Ireland must be paid in full before any further participation by the said person at any EI Competition. ie. entries will be refused.

20.5 Yellow Warning Cards and Verbal Reprimands

A Yellow Warning Card or Official Reprimand/Verbal Warning may be issued by an Eventing Ireland Steward for offences committed at an EI Event. The Yellow Warning Card must be signed by the Steward on the day and the Assistant Steward or an EI Official.

While it is clearly not possible for an EI Steward to witness all that occurs at an event, he or she should satisfy themselves that such an offence has, in all likelihood, occurred in the fashion reported to him or her.

In the case of a Yellow Warning Card being issued by an EI Steward, he or she should deliver it personally to the Athlete, together with an explanation as to why it is being issued and the possible consequences of any further offences being committed.

Official Warnings and reprimands will be delivered personally to the Athlete with an explanation as to why it is being issued and the possible consequences of any further offences being committed.

In the case of Athletes under the age of 18 years, a Parent/Guardian must be present when personally delivering the Yellow Warning Card or Official Warning.

All Yellow Warning Cards and Official Warnings must be reported within the Stewards Report for the Event

The EI Steward will advise Head Office of the issue of ALL Yellow Warning Cards, or Official Reprimands/Verbal Warnings and the reasons for the issue within 48 hours of the event.

EI Head Office will record Yellow Warning Card or Reprimand/Verbal Warning into the National Watchlist. All Yellow Cards issued will be published on the Eventing Ireland website under the Athlete Section. These records will be kept for a period of 12 months from the date of issue.

The name of the official giving the Warning or the Yellow Card and their jurisdiction at the event (eg: Steward) should be listed on the National Watchlist, along with the reason for the decision.

An Athlete receiving Two Yellow Warning Cards within a 12 month period, will incur an automatic disqualification from competition for two months, from the date of the second offence. There will be no right of appeal.

Yellow Warning Cards and Reprimands received at both International and National events will be taken into account *pursuant to FEI Article 164.3 (d) and HSI Rule Section 17.2.*

20.6 Eventing Steward – Disciplinary Powers

An Eventing Ireland Steward will be appointed to act as Disciplinary Steward at all Eventing Ireland Events.

The Eventing Ireland Steward will have limited powers on the day to reprimand, fine or disqualify (horse or Athletes) members for any transgression of the Code of Conduct of Events or acts in a manner which is adverse to the proper conduct, integrity of the Event or of Eventing Ireland. A member shall include a person competing on a day ticket and any other person associated with either an Athlete or a horse/pony competing on the day eg: owner, parent, groom. Limited powers shall cover, but shall not be limited to, matters such as no passport, continuing after elimination, failing to report to the doctor after a fall, dangerous riding, inappropriate/rude behaviour to a steward/volunteer or any Eventing Ireland official.

If in an Eventing Ireland Steward's opinion any member or any person participating in any way at Eventing Ireland events is in breach of the rules or behaves disgracefully, he or she will furnish a report to the Disciplinary Committee within seven (7) days.

The Disciplinary Committee will send a copy of the said report to the infringing Member:

- Where a member accepts the report of the Eventing Ireland Steward, the infringement will be noted on his/her record and may be expunged after six months with the prior approval of the Board.
- Where a member wishes to appeal the report of the Eventing Ireland Steward, notice of appeal, including submission setting out the grounds thereof must be made within seven (7) days of receipt of the Report.
 - On receiving the Notice of Appeal, the Disciplinary Committee Chairperson will appoint a member of the Disciplinary Committee to act as a Disciplinary Officer.
 - The Disciplinary Officer who will review the matter on the basis of the Report of the Eventing Ireland Steward, the Appeal Submission of the member and where necessary request a submission of the Eventing Ireland Steward in reply to any matters raised by the member in their appeal. No hearing will be convened by the Disciplinary Officer.
 - The Disciplinary Officer will issue a written confirmation of the decision only.

- The Disciplinary Officer will have three options in deciding the matter:
 - confirm the findings of the Eventing Ireland Steward, and the infringement noted will be expunged after one year
 - uphold the appeal of the member
 - where there is sufficient conflict or the matter raises serious concerns as to the conduct of either party refer the matter to the Disciplinary Committee for hearing

Where a member accumulates three infringements he/she will automatically be required to attend before the Disciplinary Committee.

Where a matter has been referred to the Disciplinary Committee, it may, where circumstances require, suspend the membership of the member and/or the registration of a horse pending a full hearing on a matter referred to it.

The member's name, the infringements and any action taken may be published within the Society from time to time.

20.7 Eventing Ireland Disciplinary Committee

The Eventing Ireland Disciplinary Committee will be a sub-committee of Eventing Ireland ruling body and will be composed as follows:

- i. The Disciplinary Committee will be established by the Board to determine alleged breaches of these general rules and will consist of a Chairman plus four persons nominated by the Board.
- ii. The Disciplinary Committee will be appointed annually at the ruling body's first Board meeting immediately following the Annual General Meeting each year (or at any adjourned meeting or at any subsequent meeting thereof). If a member dies or resigns, the Board may appoint a new member to fill the resultant vacancy. The member so appointed will be appointed for the remainder of the term of the member who occasioned the vacancy.
- iii. Each member will be appointed on the basis that he or she is in a position to hear issues referred to the Disciplinary Committee under these general rules fairly and impartially.
- iv. The Disciplinary Committee has the power to hear and determine all issues referred to it in accordance with these general rules.
- v. The Chairman will appoint members of the Committee to act as a Disciplinary Officer as and when required. Where a person has acted as a Disciplinary Officer in a matter that is later referred to the Committee, they will not sit on the Committee during the hearing of that matter.
- vi. The Disciplinary Committee has jurisdiction to adjudicate in disciplinary matters referred to it by a Disciplinary Officer, on matters arising through the accumulation of infringements by a member or other matters referred to it by the Board as deemed necessary.

20.8 Hearing Procedures

1. The Chairman of the Disciplinary Committee will give the person or persons concerned reasonable notice of the date, time and place of the hearing, and will send to him, her or them a written statement setting out the substance of the allegations made against him, her or them.

Where a party does not reply to a communication or fails to attend a hearing after notification, the Disciplinary Committee may deal with the matter in his/her/their absence.

2. Where necessary, the Chairman of the Disciplinary Committee will form a Hearing Committee to consider any issue where an oral hearing is required: -
 - a. The Hearing Committee will consist of three persons from the Disciplinary Committee, one of which will be the Chairman. A member of the Committee previously appointed to act as a Disciplinary Officer will not sit on the Hearing Committee in the same matter.

- b. The Hearing Committee will have all powers necessary for and incidental to the exercise of its function.
 - Subject to these rules, the Hearing Committee will have the power to regulate its procedures.
3. A member will be entitled to an in-person hearing with legal representation. If a person is to be legally represented, the person must give seven days' notice to the Secretary of Eventing Ireland with the details of their legal representative, and the Eventing Ireland Solicitor may be in attendance.
4. The Society's Eventing Steward will present the case on behalf of the complainant and will call and adduce such evidence in support of the complaint as will be necessary, to include oral evidence.
5. Hearings of the Hearing Committee will be confidential and held in private, unless the Hearing Committee decides otherwise.
6. The Hearing Committee will have the power to decide on the admissibility, relevance and weight of any evidence, and will not be bound by any legal rules in relation to such matters.
7. Each party will have the right to present evidence, make submissions, call witnesses and cross-examine the witnesses or any other party subject to the Hearing Committee's discretion to accept testimony by way of written statement or submission by fax, email or other means.
8. The Hearing Committee, at the request of one of the parties to the hearing or on its own initiative may require one or more parties to the hearing to supply it and/or the other party or parties to the proceedings, within such time as the Hearing Committee determines, further particulars of the case of that party, including details of all witnesses that party intends to call at any hearing, together with details of the evidence to be given by those witnesses, and that party will comply with that direction.
9. The Hearing Committee, at the request of one of the parties to the hearing, or on its own initiative, may direct one or more parties to the hearing to make any property, document or other thing in that party's possession or under its control available for inspection by the Hearing Committee and/or any other party, and that party will comply with that direction.
10. Any failure by any party to the hearing to comply with any requirement or direction of the Hearing Committee, including those requirements or directions to be complied with within a truncated time schedule, will not prevent the Hearing Committee from proceeding, and such failure may be taken into consideration by the Hearing Committee when making its decision.
11. A failure by any party or their representative to attend a hearing after notification will not prevent the Hearing Committee from proceeding with the hearing in their absence.
12. The Hearing Committee may postpone or adjourn a hearing.
13. The Hearing Committee will have the power, at its absolute discretion, to appoint an expert to assist or advise it. The person chosen as the expert will have no involvement in the matter before the Hearing Committee, and will be free from any conflict of interest.

20.9 Determination

The Hearing Committee will issue a written determination to both parties after the hearing in due course. Where the member accepts the Determination it will be final and binding on all parties and noted on the Member's record.

20.10 Penalties

The Eventing Ireland Disciplinary Committee, on finding that an allegation has been proved to its satisfaction, and in its absolute discretion, may impose all or any of the following penalties:

- i. Suspension of an owner, Athlete, trainer or any other person for an unlimited period from competing or participating in all Eventing Ireland activities, or any particular group or discipline.
- ii. Disqualification of a horse from an Eventing Ireland competition, event or other activity for an unlimited period.
- iii. An unlimited fine. If a fine is imposed, the person upon whom it is imposed will not participate in any competition or event until the whole of the fine is paid.
- iv. A reprimand.
- v. In addition to the imposition of any penalties as above, the Disciplinary Committee may recommend to the Eventing Ireland Board that an offender be expelled from Eventing Ireland.
- vi. The Eventing Ireland Disciplinary Committee may also expel anyone deemed to have brought Eventing Ireland into disrepute by his or her actions outside the society.
- vii. The decision of the Eventing Ireland Disciplinary Committee will be final and no appeal will lie therefrom.

20.11 Appeals

The decision of the Hearing Committee may be appealed by either party to the original decision, ie. the complainant or the member complained against, to the Chairman of Eventing Ireland.

A notice of appeal must be made in writing to the Chairman of the Disciplinary Committee within fourteen (14) days of the date of the final decision of the Disciplinary Committee.

Upon receipt of a notice of appeal, the Chairman of the Disciplinary Committee will refer the appeal to the Chairman of the Board of Eventing Ireland, who will form an Appeal Committee to consider the appeal.

The Appeal Committee will not include any members of the Disciplinary Committee who were involved in the hearing at first instance which is the subject of the appeal.

Subject to these general rules, the Appeal Committee will have the power to regulate its procedures and, subject to this power, the appeal may be conducted in accordance with the provisions of the rules of Eventing Ireland.

The Appeal Committee will have the power to impose any penalty it deems appropriate upon a member found on appeal to have breached these general rules, but within the guidelines and parameters of these rules.

The decision of the Appeal Committee will be final and binding on all parties.

20.12 Rules on Social Media

Eventing Ireland recognises that the internet provides unique opportunities to participate in interactive discussions and to share information using a wide variety of social media. However, Members' use of social media (whether they be public or private groups) can pose risks to EI's reputation and its confidential and proprietary information. It can also jeopardise its compliance with legal obligations.

Therefore, in the interests of the sport, when using the internet and all social media members must not:

- Post any threatening, derogatory, obscene, indecent, seditious, offensive, pornographic, abusive, disparaging, racist, discriminatory, menacing, inflammatory, blasphemous, or defamatory statements or material, including, but not limited to, statements or material concerning EI, its staff, its members or former members, its sponsors, affiliates and stakeholders;
- Make any statements that could directly or indirectly damage EI's name;
- Use EI logos, brand names, slogans or other trademarks, or post any of its confidential or proprietary information without EI's prior written permission.
- Bullying of any description will not be tolerated

Moreover, if members disclose or use in any way their EI membership when using social media, they must make it clear that they are speaking on their own behalf and that their views do not represent those of Eventing Ireland.

Failure by members to comply with the provisions of this Rule may result in disciplinary sanctions under these Rules and/or civil proceedings. EI may also require members to remove postings, comments or any other submissions which may constitute a breach of this Rule.

EI reserves the right to monitor, intercept and review social media postings and activities to ensure that its rules are being complied with, and for its legitimate business purposes.

EI will comply with any law, or request by any governmental or other regulatory authority, or order by a court or other authority of competent jurisdiction, requiring EI to disclose the identity or location of any Member posting any material in breach of this Rule. EI may share a member's personal information with the police or any other governmental authority if it is asked to do so in connection with the investigation of suspected illegal activities.

ONE DAY EVENTS : GENERAL GUIDANCE**21 DRESSAGE**

The FEI Dressage Rules apply for the Eventing Dressage Test at EI competitions except where otherwise provided in these Eventing Rules. Any modification introduced to the FEI Dressage Rules during the year will be evaluated for inclusion in these Eventing Rules from 1 January the following year.

All dressage tests must be carried out entirely from memory, and all movements must follow in the order set forth in the test.

21.1 Sound of bell

After the sound of the bell, the Athlete must enter the arena at A within forty five (45) seconds.

In the event that the horse starts to defecate or urinate, the clock will be stopped until the horse is ready to continue at which point the clock will be restarted.

21.2 Salute

Athletes must take the reins in one (1) hand at the salute.

21.3 Error of course

When an Athlete makes an "error of course" (takes the wrong turn, omits a movement, etc.) the Judge at C warns him, by sounding the bell. The Judge at C shows him, if necessary, the point at which he must take up the test again and the next movement to be executed, then leaves him to continue by himself. However, in some cases when, although the Athlete makes an "error of course", the sounding of the bell would unnecessarily impede the fluency of the performance - for instance if the Athlete makes a transition from working trot to medium walk at V instead of K, or makes a transition to canter at F instead of A - it is up to the Judge at C to decide whether to sound the bell or not. However, if the bell is not sounded at an error of course and the test requires the same movement to be repeated and the Athlete again makes the same error, the Athlete is only penalised once.

The decision as to whether or not an error of course has been made will be at the sole discretion of the Judge at C. The other Judges' scores will be adapted accordingly.

21.4 Error of test/execution

When an Athlete makes an "error of the execution of the test" (trots rising instead of sitting, at the salute does not take the reins in one hand, etc.) he must be penalised as for an "error of course". In principle an Athlete is not allowed to repeat a movement of the test unless the Judge at C decides on an error of course (sounds the bell). If, however, the Athlete has started the execution of a movement and attempts to do the same movement again, the Judges must consider the first movement shown only and at the same time, penalise for an error of course.

21.5 Unnoticed error

If the Judge(s) has not noted an error, the Athlete has the benefit of the doubt and will therefore not be penalised for the error.

21.6 Dressage Penalties

Error of Course

Every error of course, whether the bell is sounded or not, must be penalised, except as noted above.

First error	Two (2) points.
Second error	Four (4) points.
Third error	Elimination.

Other Errors

All of the following are considered errors, and two (2) points will be deducted per error, but they are not cumulative and will not result in elimination:

- Entering the space around the arena (Rule 0) with whip or with boots/bandages on the horse's legs or with discrepancy in dress (eg. lack of gloves)
- Entering the dressage arena with whip or with boots/bandages on the horse's legs or with discrepancy in dress (eg. lack of gloves); If the test has already started before the discrepancy has been noticed, the Judge at C stops the Athlete and if needed and possible, an assistant may enter the arena to remove the item(s). The Athlete then continues the test either starting from the beginning (from the inside of the fence) or from the movement where he was stopped. The marks given before he was stopped are not changed
- Entering the arena before the sound of the bell
- Not entering the arena within forty five (45) seconds after the bell, but within ninety (90) seconds
- Using voice or clicking the tongue repeatedly
- Athletes not taking the reins in once hand at the salute

Penalty Points

The penalty points are deducted on each Judge's sheet from the total points obtained by the Athlete.

21.7 Reasons for Elimination

Reason	Explanation
Lameness	In a case of marked lameness, the Judge at C informs the Athlete that he is eliminated. There is no appeal against this decision
Resistance	Any resistance which prevents the continuation of the test longer than twenty (20) seconds is punished by elimination. However, resistance that may endanger Athlete, horse, judges or the public will be result in elimination for safety reasons earlier than within twenty (20) seconds. This also applies to any resistance before t entering the dressage arena or when leaving the arena.
Fall	In the case of a fall of a horse and/or an Athlete, the Athlete will incur elimination (see Rules 18.2 and Rule 16.6)
Leaving Arena During Test	A horse is eliminated if, during a test, it leaves the arena when the surround is 23cms or higher.
Outside Assistance	Any outside help by voice, signs, etc. is considered as illegal or unauthorised assistance to an Athlete or to his horse. An Athlete or horse receiving positive assistance must be eliminated.
Bleeding	If the Judge at C suspects fresh blood anywhere on the horse during the test, he will stop the horse to check for blood. If the horse shows fresh blood, it will be eliminated. The elimination is final. If the Judge through examination clarifies that the horse has no fresh blood, the horse may resume and finish its test.
Other Reasons For Elimination	<ul style="list-style-type: none"> • Horse and Athlete combination not being able to fulfil the requirements of the level • The performance is against the welfare of the horse and/or shows abusive riding. • Horse and Athlete combination not entering the competition arena within ninety (90) seconds after the bell. Except where a valid reason

Reason	Explanation
	thereto has been informed to the Judge at C (valid reason may be losing a shoe, etc.) <ul style="list-style-type: none"> • Incorrect dress (Technical Elimination)

21.8 Permitted Dressage Tests

The following Dressage tests or appropriate FEI Event Test will be used unless permission has been granted by Eventing Ireland for use of a different test.

CLASSES	TEST	ARENA	APPROX TIME
EI120	Test 122 (2009)	20x60	6 mins 30
	Test 123 (2011)	20x60	6 mins 30
	Test 124 (2016)	20x60	6 mins 30
	Test 125 (2025)	20x60	6 mins 30
	FEI CCI 4* (A) 2026	20x60	6 mins
	FEI CCI 4* (B) 2026	20x60	6 mins
	FEI CCI 4* (C) 2026	20x60	6 mins
	FEI CCI 4* (D) 2026	20x60	6 mins
EI115 Adv	Test 119 (2010)	20x60	6 mins
All EI115	Test 140 (2020)	20x40	6 mins 30
	Test 115 (2011)	20x40	6 mins
	Test 116 (2016)	20x40	6 mins
	Test 117 (2009)	20x40	6 mins
	Test 118 (2010)	20x60	6 mins
	Test 139 (2025)	20x40	6 mins 30
	FEI CCI 3* (A) 2026	20x60	6 mins
	FEI CCI 3* (B) 2026	20x60	6 mins
	FEI CCI 3* (C) 2026	20x60	6 mins
FEI CCI 3* (D) 2026	20x60	6 mins	
All EI110 EI110P EI105	Test 110 (2012)	20x40	6 mins
	Test 111 (2010)	20x40	6 mins
	Test 112 (2010)	20x40	6 mins
	Test 113 (2009)	20x60	6 mins
	Test 130 (2016)	20x40	6 mins
	Test 131 (2018)	20x40	6 mins
	Test 132 (2019)	20x60	6 mins
	Test 134 (2025)	20x40	6 mins
	FEI CCI2* (A) 2026	20x60	6 mins
	FEI CCI2* (B) 2026 (inc Pony Champs)	20x60	6 mins
	FEI CCI2* (C) 2026	20x60	6 mins
	FEI CCI2* (D) 2026	20x60	6 mins
	EI105	FEI CCI1* (A) 2026	20x60
FEI CCI1* (B) 2026		20x60	6 mins
FEI CCI1* (C) 2026		20x60	6 mins
All EI100	Test 101 (2009)	20x40	6 mins
	Test 102 (2010)	20x40	6 mins
	Test 103 (2010)	20x60	6 mins
	Test 104 (2025)	20x40	6 mins
	Test 106 (2012)	20x40	6 mins
	Test 107 (2016)	20x40	6 mins
	Test 108 (2016)	20x40	6 mins
	Test 109 (2018) Championship	20x60	6 mins
All EI90 And EI80	Test 91 (2009)	20x40	6 mins
	Test 92 (2009)	20x40	6 mins
	Test 93 (2009)	20x60	6 mins
	Test 94 (2025)	20x40	6 mins
	Test 95 (2012)	20x40	6 mins
	Test 96 (2016)	20x40	6 mins
	Test 97 (2016)	20x40	6 mins
	Test 98 (2018) Championship	20x60	6 mins

21.9 Dressage Arena Layout

Arenas should be set out to the dimensions shown in the diagrams in Appendix A & B

The arena should be level and separated by a distance all round of 15m for international competitions and at least 10m for other events if more room is not available. Roping of the area should be used where necessary to prevent intrusion.

The arenas should be marked in the following ways:

- a) By a continuous surround of white boards, or
- b) By intermittent white boards placed at each corner and opposite each marker as a minimum.

The letters outside the enclosure should be placed about 0.5m from the board (with the exception of A which should be 10m back from the entrance) and clearly marked. It is helpful to place a special marker on the board itself [with coloured tape] level with and in addition to the letter concerned.

The centre line, throughout its length, and the points D, L, X, I and G, if described in the relevant test, should be clearly marked, without, however, being of a nature to frighten horses. On that account it is recommended that on a grass arena the centre line is mown shorter than the other parts of the arena, and on a sand arena the centre line is rolled or raked. The points D, L, X, I and G should be similarly mown, rolled or raked, about 2m straight across the centre line.

22 SHOW JUMPING GENERAL

The Jumping Test will be judged under FEI Rules for Jumping, except where modified in this Rule Book. The Show Jumping Officials must be given a copy of these show jumping rules.

22.1 Show Jumping Course

The course will be simple and straightforward, with easy intervals between the obstacles, and will be laid out over a distance as permitted for the class.

The course must not include compulsory turning points. It should be a test of handiness, but without sharp changes of direction. The plan should be marked showing the start and the finish, an arrow to indicate the direction in which each fence must be jumped, and the order in which the fences must be jumped. (The use of a continuous line to indicate a compulsory course is not permitted).

Red and white boundary flags mark the start and finish, but need not be used to mark the extremities of the obstacles, provided these are clearly defined.

A display/timing clock must be used during the Show Jumping phase at all Eventing Ireland events for EI105 classes and above.

22.2 Show Jumping Obstacles

Where possible, the course must be ready for inspection by Athletes, in the case of the first class, not less than one hour and in the case of subsequent classes, not less than 30 minutes before jumping is due to commence. The plan of the course showing the Time Allowed must be posted when the course is ready for inspection.

There will be 8 to 12 numbered obstacles, **numbered from 1 (for the first jump) and then in numerical order**, as solid and imposing in appearance as available materials allow. A tolerance of 5cm in height is acceptable. The first few obstacles should be inviting.

The course should normally be built to the standard height. With approval of the Eventing Ireland Steward, obstacles may be reduced in height in the event of adverse weather conditions or going, but then not by more than 5cm (2 inches).

22.3 Cups/Safety Cups

The jumping cups must have a minimum depth of 20mm and a maximum depth of 25mm.

Only Safety Cups approved by the FEI or SJI are permitted. Safety Cups must be used on the back and centre uprights of spread fences in the JUMPING and PRACTICE arenas.

22.4 Course and Obstacles

There will be 8-12 numbered obstacles. See table 22.5 below for permitted heights, widths.

EI120 CLASSES	
Maximum length	600m
Speed	375mpm
Obstacles: Max height	1.30m
(Note: only one upright and one ascending spread obstacle may be included up to the maximum height above. No other obstacle may exceed 1.25m in height)	
Maximum spread:	
at highest point	1.60m
at base	2.30m
Water trays are permitted. Water jumps not permitted.	
The course must include one double and one treble combination. There should be at least one related distance of 3 or 4 strides and the course should include not less than two square parallels.	
EI115 CLASSES	
Maximum length	600m
Speed	350mpm

EI115 CLASSES	
Obstacles: Max height	1.25m
(Note: only one upright and one ascending spread obstacle may be included up to the maximum height above. No other obstacle may exceed 1.20m in height)	
Maximum spread:	
at highest point	1.50m
at base	2.10m
Water trays are permitted. Water jumps not permitted.	
The course must include one double and one treble combination. There should be at least one related distance of 3 or 4 strides and the course should include not less than two square parallels.	

EI110 AND EI110P CLASSES	
Maximum length	500m
Speed	350mpm
Obstacles: Max height	1.15m
(Note: only one upright and one ascending spread obstacle may be included up to the maximum height above. No other obstacle may exceed 1.10m in height).	
Maximum spread:	
at highest point	1.40m
at base	1.90m
Water trays are permitted. Water jumps not permitted.	
The course must include at least one double combination and, there should be another double or a treble. There should be not less than one related distance of 4 or 5 strides and the course should include one square parallel.	

EI105 CLASS	
Maximum length	500m
Speed	350mpm
Obstacles: Max height	1.10m
(Note: only one upright and one ascending spread obstacle may be included up to the maximum height above. No other obstacle may exceed 1.05m in height).	
Maximum spread:	
at highest point	1.25m
at base	1.70m
Water trays are permitted. Water jumps not permitted.	
The course must include at least one double combination and, there should be another double or a treble. There should be not less than one related distance of 4 or 5 strides and the course should include one square parallel.	

All EI100 CLASSES	
Maximum length	450m
Speed	No Time Allowed or Time Limit
Obstacles: Max height	1.05m
(Note: only one upright and one ascending spread obstacle may be included up to the maximum height above. No other obstacle may exceed 1.00m in height). It is recommended that the first three obstacles should be lower than 1.00m to allow horses to gain confidence	
Maximum spread:	
at highest point	1.20m
at base	1.55m
Neither water jumps nor water trays are permitted	
The course must include only one double combination (not treble). There should be one square parallel.	

All EI90 CLASSES	
Maximum length	450m
Speed	No Time Allowed or Time Limit
Obstacles: Max height	0.95m
(Note: only one upright and one ascending spread obstacle may be included up to the maximum height above. No other obstacle may exceed 0.90m in height). It is recommended that the first three obstacles should be lower than 0.90m to allow horses to gain confidence	
Maximum spread:	
at highest point	1.10m
at base	1.40m
Neither water jumps nor water trays are permitted.	

All EI90 CLASSES

The course must include only one double combination (not a treble).

EI80 CLASS

Maximum length	450m
Speed	No Time Allowed or Time Limit
Obstacles: Max height	0.85m
(Note: only one upright and one ascending spread obstacle may be included up to the maximum height above. No other obstacle may exceed 0.80m in height). It is recommended that the first three obstacles should be lower than 0.80m to allow horses to gain confidence	
Maximum spread:	
at highest point	1.00m
at base	1.25m
Neither water jumps nor water trays are permitted.	
The course must include only one double combination (not a treble).	

22.5 Heights, distances and speeds

Class	EI120	EI115	EI110 EI110P*	EI105	All EI100	All EI90	EI80
Max Course Length	400-600m	400-600m	400-500m	400-500m	450 m	450 m	450 m
Speed per min	375 m/m	350 m/m	350 m/m	350 m/m	N/A	N/A	N/A
Standard Height	1.25m	1.20m	1.10m	1.05m	1.00m	0.90m	0.80m
Max Height	1.30m	1.25m	1.15m	1.10m	1.05m	0.95m	0.85m
Min Height	1.20m	1.15m	1.05m	1.00m	0.95m	0.85m	0.75m
Max spread at highest point	1.60m	1.50m	1.40m	1.30m	1.20m	1.10m	1.00m
Max spread at base	2.30m	2.10m	1.90m	1.70m	1.55m	1.40m	1.25m
Water Trays	Permitted				Not Permitted		
Water Jumps	Not Permitted						

EXCEPTION: One upright and one ascending spread obstacle may be included in the course, up to the maximum height above. The rest of the obstacles must be at the standard height.

Young Rider and Junior dimensions and speeds will be as the relevant senior class.

*** Note for EI110P Class**

Only by special agreement made in advance with the HSI High Performance Manager, SJ Course Designer and Event Organiser will the EI110P course be changed to pony distances. One double must be included in the EI110 pony class.

The set time for the Jumping Phase of the EI110P (when the combinations are set at pony distance) will be agreed and published on the notice board or the event.

22.6 Jumping Combinations:

Courses for EI120, EI115, EI110, EI110P and EI105 classes may include one double or one treble combination or both. Courses for EI100, EI90 and EI80 may only include one double combination (not treble).

22.7 Show Jumping Penalties

FAULT	PENALTY
Knockdown	4 penalties
First disobedience	4 penalties
Second disobedience in whole test	Elimination
Fall of Athlete	Elimination
Fall of horse	Elimination

FAULT	PENALTY
Error of course not rectified	Elimination
Omission of obstacle or boundary flag	Elimination
Retaking an obstacle already jumped	Elimination
Jumping an obstacle in wrong order	Elimination
Incurring 20 or more jumping penalties (excluding time) (to be enforced at the end of the round unless Athlete retires)	Elimination
Time Faults for every commenced second in excess of the time allowed (for EI105 classes and higher)	0.4 penalty
Exceeding the Time Limit (which is twice the time allowed)	Elimination

22.8 Elimination

- An Athlete who is eliminated must leave the arena and take no further part in the test.
- Strictly no fence can be jumped following elimination resulting from a fall.
- For classes where the Jumping test is before the Cross Country test, an Athlete incurring 20 or more jumping penalties during the Jumping test will not be authorised to start in the Cross Country test and will be automatically eliminated from the competition

22.9 Statutory Elimination

- Failure to pass on the correct side of a directional flag.
- Exceeding the time limit
- Second disobedience during the course of a round anywhere on the course
- Failure to re-attempt an obstacle after a run-out.
- Fall of Athlete during the course of a round anywhere on the course.
- Fall of horse during the course of a round anywhere on the course.
- Crossing the starting line prematurely and attempting to jump or jumping an obstacle.
- After being stopped by the Judge or stopping involuntarily, continuing before the bell.
- Re-attempting an obstacle, which has been disturbed, before the bell.
- Failing to re-attempt an obstacle following a first or second disobedience.
- Failure to re-attempt all obstacles of an open combination.
- Jumping an obstacle in the wrong order or in the wrong direction.
- Jumping an obstacle that does not form part of the course.
- Attempting an alternative obstacle before the bell when the other obstacle has been disturbed as the result of disobedience
- Failing to jump the next obstacle within 60 seconds.
- Knocking over the timing equipment.
- Improperly leaving the arena.
- Failing to cross the finishing line mounted.
- Failing to leave the arena mounted and by the designated exit, unless injured.
- Jumping or attempting to jump any obstacle or passing through the finish without protective headgear on.

22.10 Technical Elimination

At the discretion of the Eventing Ireland Steward / Judge(s), an Athlete may be eliminated for the following reasons.

- Unauthorised access to the arena
- Starting out of order
- Failure to enter the arena mounted and through the designated entrance
- Failure to enter the arena within one minute of being called
- Failure to commence the round within 45 seconds after the bell
- Ignoring the bell when required to stop during a round
- Receiving unauthorised assistance
- Jumping any obstacle without protective headgear when committed to jumping at the moment when the headgear comes off
- Riding improperly dressed. See Rule 11

22.11 Practice Obstacles

For diagrams of practice fences that are not permitted, see Appendix I.

- a) The course builder is responsible for ensuring that a minimum of one upright and one spread obstacle is provided in each practice area with appropriate flags. These obstacles are intended for warming up purposes immediately prior to competing and must be constructed in the usual manner. They are not to be used for prolonged schooling by Athletes or others immediately before, during or after a competition. Only material provided by the event may be used in the practice area for this purpose. This area should be stewarded and preferably roped off from the public.
- b) All elements of practice obstacles must be capable of being knocked down in the normal manner and must not be fixed, jammed or positioned in a manner which prevents or hinders them from falling. One pole only may be laid flat on the ground at the ground line vertically below the front edge of the first element of the obstacle, or up to 1m (3'3") in front and parallel to it on the take off side. At least one end of any pole or plank forming part of a practice obstacle must be supported by a juard cup or fitting. Sloping poles are permitted on straight obstacles and on the front element only of spread obstacles, provided the top end is not placed higher than the horizontal pole and the unsupported end of the sloping pole must rest at or in front of the ground line. False ground lines are not allowed. Alternate sloping top poles are not to be used. See Appendix I.
- c) Practice spread obstacles are not to be jumped in such a direction that the front element is higher than the rear element.
- d) Practice obstacles **MUST** be jumped in one direction only. The direction in which the obstacle is to be jumped must be indicated with red and white flags or by red and white supports. The red flags or supports must always be passed on the Athlete's right hand side and the white flag or support on the Athlete's left hand side. Failure to comply with this rule will result in elimination.
- e) The height of practice obstacles must not exceed the following table:

All Classes	EI120	EI115	EI110/ EI110P	EI105	EI100	EI90	EI80
Max Height	1.35m	1.30m	1.20m	1.15m	1.10m	1.00m	0.90m

- f) No placing poles are allowed.
- g) An Athlete may be eliminated for contravening any part of this Rule, especially for jumping the practice fence in the wrong direction
- h) No part of any obstacle may ever be held by anyone whilst a horse is jumping it.



**KLS EQUINE
PRODUCTS**

The Leading Name in Equestrian Training Equipment Across Ireland



Showjumps | Portable Cross Country | Dressage arenas



KLS Equine Products



23 CROSS COUNTRY

There is no limit to the number of course changes on any one day, however Event Organisers must consider the time of year/number of daylight hours and the number of expected entries to ensure the event finishes whilst there is good light.

23.1 Prior Knowledge

No Athlete may, under penalty of elimination at the discretion of the Eventing Ireland Steward, compete other than 'hors concours' on a horse which has had the opportunity to practice over any of the obstacles, except where the course is generally available for schooling, when no Athlete may have practiced over any of the obstacles to be used in the competition after the close of entries.

23.2 Access to the Cross Country Course

The course must be officially opened for inspection on the day preceding the cross country by 2.00pm at the latest. Athletes may not inspect the course prior to this time. The course may only be inspected on foot.

23.3 Plan of XC Course

A plan of the course must be displayed by the time the course is open for inspection by Athletes. This plan must include:

- a) The course to be followed and its length, with the Optimum Time and the Time Limit
- b) The numbering of the obstacles
- c) Any compulsory flags or turning points.
- d) Class Indicator Flags (see Rule 23.16) must be notified at the first fences

23.4 Method of Starting

Athletes ideally should start from within a simple enclosure which may be erected at the start, measuring approx. 5 metres (16ft) square, with an open front, marked with a red and white flag. Alternatively a similar sized enclosure may be used with an open front and a gap in one or both sides, from which horses will enter. The starter will count down from five before giving the signal to start and provided the Athlete does not cross the start line before the signal to start is given, the Athlete may move around the enclosure as he pleases. Cantering through a side-entrance may be considered "inappropriate or dangerous riding" and may be penalised under Rule 10.2 Dangerous Riding.

Assistance within the starting enclosure is permitted, provided it ceases immediately the signal to start is given. From that instant the Athlete is considered to be on the course and subsequent assistance is forbidden. (See Rule 23.11 Unauthorised Assistance).

23.5 Time Keeping

Time is counted from the moment the horse's nose crosses the start line until the instant when the horse's nose passes the finishing post.

An Athlete is under the control of the starter and may not start until instructed to do so by the starter, under penalty of elimination at the discretion of the Steward. If an Athlete starts early the time will be recorded from the moment the horse's nose crosses the start line.

Time is counted in whole seconds, fractions being taken to the next second above, eg. 30.25 seconds is recorded as 31 seconds. Periods during which an Athlete has been held up by a fence judge or official will be deducted from the above time, to give the correct time for completing the course.

In the event of a timing error the EI Steward is allowed to make an accurate estimate of an Athlete's time, utilising official times taken around the course (See Rule 9.7).

23.6 Errors of Course

All compulsory passages and all obstacles, including all elements and / or options, must be passed or jumped in order, under penalty of elimination. All red or white flags must be respected wherever they occur on the course, under penalty of elimination (except as provided in Rule 23.26 Definition of Cross Country Penalties). Retaking an obstacle already jumped in whichever direction is forbidden, under penalty of elimination (except as provided in Rule 23.26 Definition of Cross Country Penalties).

23.7 Pacing and Dismounting

Between the start and finish of the Cross Country, Athletes are free to choose their own pace as indicated in Rule 23.19 and they may voluntarily dismount without incurring elimination to check on horse, adjust saddlery or equipment. In this situation, no outside assistance is permitted.

Athletes must also have regard to and respect the class speed and the optimum time.

Deliberately slowing down or taking actions that would lead to a competitive advantage near the end of the cross country course to avoid time penalties is likely to incur disciplinary action.

23.8 Overtaking

Any Athlete who is about to be overtaken by a following Athlete must quickly clear the way. Any Athlete overtaking another Athlete must do so only at a safe and suitable place and must let the slower Athlete know they are doing so.

When the leading Athlete is before an obstacle and about to be overtaken he must follow the directions of the Fence Judges. When the leading Athlete is committed to jumping an obstacle, the following Athlete may jump that obstacle only in such a way that will cause no inconvenience or danger for either.

The penalty for willful obstruction of an overtaking Athlete, failure to follow the instructions of the Fence Judges, or causing danger to another Athlete is elimination at the discretion of the Eventing Ireland Steward.

23.9 Athletes in Difficulty

If, in attempting to negotiate an obstacle, a horse should become trapped in such a way that it is liable to injure itself or be unable to proceed without assistance, the Steward shall decide if parts of the obstacle shall be dismantled, or if any other assistance shall be given to extricate the horse.

In such a case, the Steward will first instruct the Athlete to dismount and he will be eliminated.

23.10 Stopping Athletes

If any part of an obstacle is obstructed by an Athlete in difficulty, or if any obstacle has been dismantled to release a fallen horse, or if an obstacle has been broken and is not yet rebuilt, or in any other similar circumstances, subsequent Athletes must be halted.

In such a case a stopping point should be chosen in the path of an oncoming Athlete. As the Athlete passes this point at competition pace, their time will be taken and recorded. When the instruction is given to restart the competition, the Athlete will restart and their time will again be taken and recorded as they re-pass the stopping point at competition pace.

Athletes must not be slowed down before passing the stopping point or restarted from a halt. Any signal to stop must be given clearly and only after the Athlete has passed the stopping point.

A Fence Judge or Steward will stop Athletes only upon the instructions of Control or during an emergency at his obstacle.

The time during which the Athlete was stopped will be deducted from the total time taken by the Athlete to complete the course.



23.11 Unauthorised Assistance

Any intervention by a third party, whether solicited or not, with the object of facilitating the task of the Athlete or of helping his horse, is considered unauthorised assistance and the Athlete is liable to be eliminated.

In particular, the following are forbidden:

- a) Intentionally to join another Athlete and to continue the course in company with him;
- b) To be followed, preceded or accompanied, on any part of the course, by any vehicle, bicycle, pedestrian or horseman not in the competition.
- c) To post friends at certain points to call directions or to make signals in passing.
- d) To have someone at an obstacle to encourage the horse by any means whatsoever.
- e) To tamper with the obstacles or any part of the course, including, for instance, flags, indicators, markers, notices, ropes, trees, branches, wire or fences, wherever temporary or permanent.
- f) The use of receiving, recording, transmitting or monitoring devices, other than by the Officials of the Event by Athletes is strictly forbidden while mounted during any test.
- g) The use of Drones anywhere at an event is strictly prohibited.

Officials or spectators who draw the attention of an Athlete to a deviation from the course are giving outside assistance, which may result in the elimination of the Athlete.

The Eventing Ireland Steward will decide each case of outside assistance.

23.12 Exceptions

Whip, Headgear or Spectacles may be handed to an Athlete without dismounting.

23.13 Emergency Flags

At all Events, where signaling flags are available, they will be used to summon assistance as follows:

RED	Medical Officer and/or Paramedic
BLUE	Veterinary Surgeon
WHITE	Fence Repair

Flags should be waved overhead until the signal is acknowledged.

23.14 Marking of the XC Course

Red or White boundary flags are used to mark the start and finish and compulsory sections of the course, to define the limits of obstacles and to indicate compulsory changes of direction. They are placed in such a way that a horse and Athlete must have a red flag on his right hand side and a white flag on his left. Such red or white flags must be respected, under penalty of elimination, wherever they occur on the course, whether singly or in pairs.

Direction markers or signs are normally yellow in colour and circular in shape and are intended merely to show the general direction to take and help the Athlete find his way. Passing close to them is not obligatory.

23.15 Safety Flags

The types of fence required to use Safety Flags include:

- a) Corners
- b) Fences of less than 3 metres jumpable width
- c) Related fences which because of their design offer a jumpable line of less than 3 metres width.
- d) Fences where horses are required to be within 2 metres of a flag
- e) Fences jumped on an angle where knocking a flag is a possibility.

The Flags and poles on these fences must meet the following criteria:

- a) The flag poles must be made of a material that cannot shatter, break or splinter, such as suitable plastic, carbon fibre or any other appropriate materials. Wooden poles are not acceptable.
- b) Flag poles must extend above the jump so it is clear where it is to be jumped
- c) There must be no points anywhere on the flag poles and any sharp corners and /or edges on the flags must be rounded.
- d) There must be no "open-ends" of any part of the flag poles which may come into contact with horse or Athlete.
- e) Flags must be secured in such a way that they break-away from the fence if /when struck either by horse or Athlete in such a way that the change of horse and/or Athlete being injured is significantly reduced.

All flag and flag poles to be used in these situations will have to be approved by Eventing Ireland Steward.

23.16 Class Indicator Flags

For the convenience of Athletes when they are inspecting the course, coloured indicators will be used to mark the obstacles for the different classes.

Course Colour	Class
Blue	E120
Green	E115
Yellow	E110 and E110P
Black	E105
Pink or Red	E100 and (T)
Orange	E190 and (T)
Purple	E180 and (T)

Where different parts of the same obstacle are to be jumped by more than one class, the section of the obstacle applicable to each class must be clearly marked at each end with the appropriate class indicator.

A Black Line on both side of the flags indicates obstacles with alternatives.

Boundary flags and direction markers will be large and placed in a conspicuous position.

All obstacles, boundary flags, direction markers and class indicators which have to be observed by Athletes must be exactly in position by the time the course is open for inspection by Athletes and any variations in the course for the different classes clearly marked.

Before commencement of each class, the boundary flags must be re-positioned, where necessary, so that they exactly define the course for the class concerned. An Athlete must not jump an obstacle with crossed flags. The penalty for this is elimination. NB: Inoperative flags **MUST NOT** be displayed where obstacles for different classes are adjacent.

Unless specifically told by an official, all obstacles must be jumped as per the Course Map – this includes fences where a flag may have been dislodged by the previous Athlete.

23.17 Fences with Frangible/Breakable Devices

Fences fitted with breakable devices are designed to be capable of being knocked down under certain conditions and must be shown on the course plan. They are judged like any other fence. When the breakable device is activated, it must be replaced/repared before the next Athlete jumps the fence. If an Athlete breaks or activates the frangible device following a refusal at the fence, and retakes the jump when it is still broken, they will automatically be eliminated.

23.18 Modification of the Course

After the course is open for inspection by Athletes, no alteration may be made, except that, where exceptional circumstances (such as heavy rain) make one or more obstacles unfair or dangerous, the Eventing Ireland Steward may require a reduction in the severity or permit Athletes to by-pass such obstacles. In such a case, the Cross Country Steward and Starter and every Athlete must be officially and personally informed of the proposed alteration before the start of the test. An official may have to be stationed at the place where the alteration has been made, in order to warn the Athletes.

If it is necessary in the interest of safety for the Eventing Ireland Steward to order an obstacle to be by-passed or omitted during a section, all jumping faults previously incurred in that section at that obstacle shall be cancelled with the exception of elimination and retirement. An Athlete who has been eliminated or has retired shall NOT be reinstated in the competition. Once taken out, the obstacle shall NOT be reintroduced in that section. **The Eventing Ireland Steward will decide what arbitrary adjustment shall be made to the Athletes times.**

23.19 Distances, Speed and Jumping Efforts

Class	EI120	EI115	EI110	EI110P
Distance (m)	3200-4000	2800-3600	1800-3000	1800-3000
Speed m/min	570	550	520	500 - 520
Jumping Efforts	25 – 35	22 – 32	18 - 30	18 - 30

Class	EI105	All EI100	All EI90	EI80
Distance (m)	1800-3000	1600-2800	1600-2800	1600-2800
Speed m/min	500	475	450	435
Jumping Efforts	18 - 30	18 – 25	18-25	18-25

The total number of jumping efforts shall be within the limited (minimum and maximum) shown in the Table of Distances, Speeds, Times and Jumping Efforts for the relevant level of Competition.

The efforts to be counted are the efforts on the route expected to be taken by the average horse.

For all classes at all levels it is possible to have a maximum of an additional 2 efforts whereby steps and ditches do not necessarily count as efforts under the following conditions:

- a) 2 steps as part of a combination/related fences may only count as one effort, eg a sunken road with what would traditionally be 4 efforts (fence before, step down, step up, fence after) may count as 3 efforts
- b) 3 steps up or down will count as 2 efforts
- c) a ditch as part of a combination (e.g. a hollow/coffin type fence) does not count as an effort
- d) **Step down as part of a combination need not necessarily be counted as an effort provided that any such step does not exceed the maximum permitted height of an obstacle for the Competition. Steps up that do not exceed 75% of the maximum permitted height of an obstacle for the Competition need not necessarily count. The Course Designer and Steward need to agree, in advance of the competition, how many of such efforts, if any, are appropriate for the particular competition given the nature of the terrain and the balance, flow, and intensity of the course. If a step or a ditch is clearly an 'effort', it should be counted as such**

NB: In exceptional circumstances the maximum distance and number of jumping efforts may be extended but only with the recommendation of the Eventing Ireland Steward and the agreement of the Organiser / Land Owner and the permission of Eventing Ireland.

EI110YR and EI110J Cross Country length, speed and jumping efforts will be as the equivalent Senior Class. However the EI115J cross country speed is 520m/min even if the competition is of intermediate standard.



The optimum time for completing the course is calculated at the speeds shown here. Exceeding this optimum time incurs **0.4 penalties for every second**, up to the time limit, which is twice the optimum time. Exceeding the time limit incurs elimination.

To arrive at the number of jumping efforts, the efforts on the route expected to be taken by the average horse shall be totalled.

23.20 Cross Country Obstacles

- a) An obstacle is considered as such if and only if its extremities are marked with a red and white flag or flags and it is numbered. All significant jumping efforts that the average horse may be expected to attempt to negotiate must be defined as an obstacle or element and flagged, numbered and/or lettered accordingly.
- b) Obstacles must be solid, fixed and imposing, designed to suit the quality and state of preparation of the competitors expected to take part. Where natural obstacles (eg. hedges) are used they must be reinforced as necessary, so that they present as far as possible the same problem throughout the competition. All reasonable precautions must be taken to prevent the possibility of a competitor being able to pass mounted under an obstacle. Portable fences must be secured to the ground in a way that the fence cannot move.
- c) Obstacles at which a horse, in falling, is liable to be trapped or to injure itself, must be secured by rope in such a way that parts of the obstacle can be quickly dismantled and rebuilt exactly as before. Such a construction must not in any way detract from the solidity of the obstacle.
- d) In all water crossings, the bottom should be firm and consistent.
- e) Obstacles may have elements or options as follows.
 - i. **Obstacles composed of several elements**

If two or more jumping efforts, sited closely together, are designed as one integral test, they will be designated as "elements" of a single numbered obstacle. Each element will be marked with a different letter (A, B, C, etc.) and must be negotiated in the correct order.

Where two or more jumping efforts are sited so closely together that after a refusal, or run-out it would be unreasonably difficult to attempt to negotiate the second or subsequent effort without retaking one or more earlier efforts, these jumping efforts must be designated as one numbered obstacle and lettered accordingly.
 - ii. **Cross Country Fences with Elements**

For diagrams of cross-country fences with several elements see Appendix F.
 - iii. **Obstacles with Alternatives**

Where an obstacle may be jumped in one effort but has options involving two or more efforts, each of these options must be lettered or numbered as an element.
 - iv. **Black Flagged Alternatives**

Alternative obstacles or elements may be flagged separately and must be identified by the same number / letter as on the direct route. In this case, both sets of flags must be marked with a black line on both sides of the flag.
- f) **Adjacent**

If two or more obstacles, although sited close together are designed as separate problems, each will be numbered and judged independently. A competitor may circle between them without penalty, providing that this is not as a result of attempting to negotiate an obstacle. He must not, under penalty of elimination, retake any obstacle, which he has already jumped.

g) **Practice Fences**

These should be separate to those used for the Show Jumping and, if possible, of a solid construction, flagged and secured to the ground.

23.21 Cross Country Intervals

The following are the recommended minimum time intervals allowed between Athletes going cross country:

Class	Minimum Interval
EI120	2 minutes or 90 seconds
EI115	90 seconds
EI110	90 seconds
EI105	90 seconds
EI100	60 seconds
EI90	
EI80	

Under no circumstances should Athletes be running at less than one minute intervals.

23.22 Measurement of Cross Country Obstacles

THE HEIGHT of an obstacle is measured from the point where the average horse would take off. The spread of an open obstacle (eg. Oxer or Ditch) is measured from the outside of the rails or other material making up the obstacle on the line where the average horse is expected to jump. The spread of a closed obstacle with a solid top (eg. Tables) is measured from the highest point to the highest point on the line where the average horse is expected to jump. Base spread measurements include all solid element/rails, including solid ground lines (please refer to the [FEI Cross Country Guide for Officials](#) for details).

OBSTACLES of the Cross-Country Test: the maximum height of the fixed and solid part of a hedge or brush fence must never exceed the dimensions specified. The overall height of a hedge or brush fence must never exceed to the dimension set. The fence must be constructed so that a horse clearing the fixed and solid part is unlikely to be injured by the brush or hedge. Bullfinches, ie. thin brushes or hedges through which a horse can be expected to jump, are permitted, provided they can be maintained in consistent condition throughout the test.

When the height of an obstacle cannot be clearly defined (natural hedge or brush fence), the height is measured to the fixed and solid part of the obstacle through which a horse cannot pass with impunity.

As per Course Designer Guidelines, at least 75% of XC fences on each track must be up-to-height

23.23 Type of Obstacles

Fence Type	Dimension Description
Drop Fences	The drop on the landing side of an obstacle is measured from the highest part, including from the top of a brush fence, of the obstacle to the spot where the average horse would land.
Water	At obstacles involving water crossings (ford, lake or wide river), the depth of water, from the entrance to the exit, must not exceed 35 cm. The length of any water crossing must be at least 6 metres between entry and exit, except where an exit step(s) or fence is jumped directly out of the water, in which case the minimum length must be 9 metres. This same minimum length must apply where a horse is expected to jump down into and up from a dry ditch such as a "Sunken Road".

Fence Type	Dimension Description
Overhead Obstructions	Any roof or other fixed and solid barrier over an obstacle must be not less than 3.36m above ground level.
Spreads	At obstacles with spread only (dry or water-filled ditch), a guard rail or hedge in front that facilitates jumping is permitted. It may not exceed 50cm in height and must be included in the measurement of the spread.
No of Drops	The number of obstacles at EI115 and EI110 events with a compulsory drop exceeding 1.60m is limited to two. At EI110 classes, no compulsory drops over 1.60 metres are permitted.

23.24 Permitted Dimensions of Obstacles

The dimension of obstacles must be within the limits shown for the relevant level of competition.

The fixed and solid part of an obstacle may not exceed the specified height or spread at any of the points at which an Athlete might reasonably attempt to negotiate the obstacle.

The following table gives the maximum permitted dimensions of obstacles for each class, but this does not mean that obstacles must always be of uniform height or spread throughout their length, or that these dimensions may never be exceeded anywhere between the red and white flags marking the extent of an obstacle.

It is sufficient if ALL parts of an obstacle, where the average horse and Athlete could reasonably and conveniently be expected to jump, does not exceed the maximum permitted dimensions.

The spread of an obstacle will be measured from the outside of the relevant rails or other material making up the obstacle.

For the diagram of the measuring of spread fences, see Appendix G .

Obstacles	EI120	EI115	EI110 EI110P	EI105
Max Height	1.20m	1.15m	1.10m	1.05m
Max Spread at Highest Point	1.80m	1.60m	1.40m	1.20m
Max spread at base	2.70m	2.40m	2.10m	1.80m
Max spread without height	3.60m	3.20m	2.80m	2.40m
Max spread over water	4.00m	3.65m	3.05m	3.05m
Drop fences: Max drop	2.00m	1.80m	1.60m	1.40m
Max depth Jumping in & out of water	0.35m	0.30m	0.30m	0.30m
Brush	1.40m	1.35m	1.30m	1.25m

Obstacles	All EI100 Classes	All EI90 Classes	EI80 Classes
Max Height	1.00m	0.90m	0.80m
Max Spread at Highest Point	1.10m	1.00m	0.90m
Max spread at base	1.80m	1.50m	1.25m
Max spread without height	1.80m	1.20m	1.20m
Max spread over water	3.05m	2.00m	2.00m
Drop fences: Max drop	1.40m	1.30m	1.20m
Max depth Jumping in & out of water	0.20m	-	-
Brush	1.20m	1.10m	1.00m

In exceptional circumstances the Eventing Ireland Steward is authorised to reduce the severity of, or to bypass obstacles, or to reduce the distances or the speeds demanded.

**23.25 Cross Country Errors and Penalties**

Cross Country Errors	Penalty
First refusal, run-out, circle of horse at obstacle	20 penalties
Second refusal, run-out, circle of horse at same obstacle	40 penalties
Third refusal, run-out, circle of horse at same obstacle	Elimination
Third cumulative refusal on the Cross Country course	Elimination
Fall of Athlete anywhere on cross country course	Elimination
Fall of horse anywhere on cross country course or when trapped in a fence in such a way that it is unable to proceed without assistance or is liable to injure itself	Elimination
Activating a frangible device where the dimension of the fence is modified	11 penalties
Error of course not rectified	Elimination
Omission of obstacle or boundary flag	Elimination
Retaking an obstacle already jumped	Elimination
Jumping an obstacle in wrong order	Elimination
Jumping wrong fence	Elimination
Jumping an obstacle with crossed flags	Elimination
For every second in excess of the Optimum Time	0.4 penalties
For every commenced second in excess of 30 seconds under the optimum time	0.4 penalties
Exceeding the Time Limit (which is twice the optimum time)	Elimination
Inappropriate or dangerous riding	25 penalties See Rule 10.2
Riding improperly dressed	Discretionary Elimination
Deliberately starting early	Discretionary Elimination
Activating a breakable device where the dimension of the fence is modified	11 penalties
Missing a Flag **	9 penalties
Reattempting an activated frangible fence element not correctly restored to its original condition	Elimination

Note: For instances in which a Fall has occurred in the same movement as a refusal, activation of a breakable device, or missing a flag, the points related to the additional fault will not be counted towards the results (eg., a Horse refuses, causing the Athlete to fall will not cause the combination to incur 20 penalties for the refusal). These must, however, be reported in the Cross Country Fence Analysis.

For the avoidance of doubt, in no case should the points related to activating a frangible device be removed, unless specified in the previous note.

There will be no Appeal against the decision of the Eventing Ireland Steward arising from the field of play, where the decision is based on factual observation of the performance during the competition.

In this case, a detailed report explaining the reasons for removing the penalty must be produced by the Course Designer/Technical Delegate and signed by the Eventing Ireland Steward and sent to Eventing Ireland Head Office.

23.26 Definition of Cross Country Penalties

The following faults (refusal, run-out, circling) will be penalised only if, in the opinion of the judge concerned, they are connected with the negotiation or attempted negotiation of a numbered obstacle or element.

In the case of **black flag** alternatives only one obstacle/element has to be jumped and an Athlete is permitted to change without penalty from one **black flagged** line to another (eg. jumping 6a left hand route then 6b right hand route) provided he has not presented his horse at the next element of the original line.

In the case of **black flag** alternatives the faults at obstacles (refusal, run out, circle) will only be penalised if related to the obstacle/elements attempted or negotiated (elements not attempted or negotiated will be irrelevant of the judging of such alternatives).

When there is any doubt about the correct interpretation of the rules of judging any element, obstacle or combination of obstacles, it is recommended that the Eventing Ireland Steward should approve the instructions to officials, with a rough sketch of the particular obstacle[s] in question, which should also be posted with the Course Plan.

XC Penalty	Definition
Refusal	<p>Obstacles With Heights: At obstacles or elements with height (exceeding 30cm), a horse is considered to have refused if it stops in front of the obstacle to be jumped. Jumping from a standstill is not permitted and will be considered as dangerous riding, please see Rule 10.2</p> <p>Obstacles Without Height: At all other obstacles (ie: 30cm or less in height) a stop followed immediately by a standing jump is not penalised, but if the halt is sustained or in any way prolonged, this constitutes a refusal. The horse may step sideways but if it steps back, this is a refusal.</p> <p>Multiple Refusals After one refusal, if an Athlete redoubles or changes his efforts without success, or if the horse is represented at the obstacle after stepping back and stops or steps back again, this is a second refusal; and so on. Two refusals at the same fence will result in 60 penalty points (20 for first refusal plus 40 for the second refusal).</p> <p>Three refusals anywhere on course results in elimination</p>
Run Out - Missing a Flag	<p>a) Clear (0 penalties): A horse is considered to have cleared the fence when the head, neck and points of both shoulders pass between the extremities of the obstacle as flagged. If a flag is dislodged, the hindquarters must jump the height of the solid part of the obstacle.</p> <p>b) Missing a flag (9 penalties): A horse is considered to have missed a flag when the point of a shoulder fails to pass between the extremities of the obstacle as flagged. The head and neck must pass inside the extremities of the obstacle as flagged. If a flag is dislodged, the hindquarters must jump the height of the solid part of the obstacle</p> <p>c) Run-Out (20 penalties): A Horse is considered to have run out if, having been presented at an obstacle on the course, it avoids it in such a way that the head, neck and point of either shoulder fail to pass between the extremities of the obstacle as flagged or the hindquarters have not jumped the height of the solid part of the obstacle. Continuing on course without representing will incur elimination.</p>
Judging of Bounce Obstacles	<p>At any obstacle where the distance between elements is 5 metres or less (ie: a bounce), when a horse has negotiated the first element without penalty, he will be deemed to have been presented at the second element – and similarly if the bounce is for example the second and third elements of a combination. Thus if an Athlete “changes his mind” while negotiating the first element of a ‘bounce’ and, for example, then goes a longer route, he will still be penalised 20 penalties for a run-out.</p>

XC Penalty	Definition
Circle	<p>Separately Numbered Obstacles At separately numbered obstacles, an Athlete may circle or cross his tracks between or around them without penalty provided he has not presented his horse at the second or subsequent obstacles.</p> <p>Obstacle Composed of Several Elements At an obstacle composed of several elements (A, B, C, etc.) a Horse will be penalised once it has jumped the first element and before it has jumped the last element if:</p> <ol style="list-style-type: none"> a) It passes around the back of the next element of the lettered combination that it subsequently jumps. b) It crosses its tracks between the elements. c) It circles back around any element that it has already jumped before jumping any subsequent element of a lettered combination <p>Representing After a Disobedience After being penalised for a refusal, run-out or circle, an Athlete, in order to make another attempt, is permitted to circle one or more times without penalty, until he again presents his horse at the obstacle.</p> <p>At an obstacle composed of several elements if the Athlete refuses, runs out or circles at any element, he is permitted to retake any elements already jumped, although he is liable to be penalised for any fault even if he has previously jumped an element successfully.</p> <p>If, after a refusal, run-out or circle, the Athlete wishes to pass through flags of a fence without height (ie. step or ditch 30cm or less) in the wrong direction in order to retake an element, the Athlete may do so without penalty.</p>

**** Frequently Asked Questions regarding Missing Flag/Jumping Outside Flag**

Question	Answer
Q: Could a combination be penalised with 9 penalties several times on the course?	Yes, as long as the horse clearly attempted to jump the fence
Q: If a combination jumps the fence between the flags and the Athlete thinks he jumped outside of the flags and jumps fence again is it an elimination for jumping a fence twice?	This combination would not be eliminated or penalised with 9 penalties, they would be marked clear but no time penalties would be removed.
Q: How will it be judged if the horse is scored clear the first time, is represented and runs out on representation?	The combination would get time penalties only. No penalties for second disobedience at a fence already judged as jumped clear.
Q: If a combination jumps a fence between the flags and the Athlete thinks he jumped outside of flags, repeats fence and breaks a frangible device at 2nd attempt, will the combination be penalised with 11 penalty points?	This combination would neither be penalised with 9 penalties nor 11 penalties but no time penalties would be removed.

INTERNATIONAL EVENTS

24 GENERAL GUIDANCE

All international horse sports are governed by the rules of the Federation Equestre International (FEI). The FEI deals directly with the national Federations (NFs). Our National Federation is Horse Sport Ireland (HSI).

This section of the EI Rule Book contains references and extracts from the FEI General Regulations, Eventing Rules and Veterinary Regulations; All of these rules are set out in full at <https://inside.fei.org/fei/disc/eventing/rules>. All Athletes and owners are advised to read these rules in conjunction with the rules below.

Explanation of abbreviations	
CCI-S	One Day International
CCI-L	Three Day International
CI	Either a One Day or a Three Day International

Senior, Young Rider and Junior CI Events are open equally to horses and ponies, provided they and their Athletes meet all the relevant qualifications.

Registrations (Article 500.2.4 FEI rules)

All horses and Athletes competing in International Events must be registered with the FEI by way of the national Federation (HSI); Details are obtainable from the HSI website <https://www.horsesportireland.ie/team-ireland/fei-passports/>

Horses Passports (Article 137 FEI General Regulations)

Horses entered at CI's (CIs 2*/3*) in a foreign country, and all horses entered at other CI's (CCI4*-S and CCI4*/5*-L), CIOS, FEI Championships, Regional and Olympic Games whether at home or in foreign countries, must have a valid FEI Passport or a National Passport approved by the FEI and inserted inside an FEI recognition Card as a means of identification and to establish ownership. All horses/ponies must be registered annually.

Horses taking part in CI's (CIs 2*/3*) in the country in which they are resident are not required to have such a passport as mentioned above. All such horses must be properly registered with their NF and identifiable and, unless there is no national requirement for vaccination in the host country and in the country of origin, all horses must have a valid vaccination certificate.

All horses newly registered with the FEI must be identifiable with a Microchip, compatible with ISO 11784 and ISO 11785. All microchip information must also be entered into the horse's passport.

25 SELECTION FOR HSI HIGH PERFORMANCE SQUADS

Selection for HSI High Performance Squads in all age groups, is the responsibility of the Horse Sport Ireland HSI High Performance Managers. The HSI High Performance Managers will be appointed by HSI.

25.1 Senior Athlete Selection

Senior Athletes must make themselves known to the HSI High Performance Manager, so that their performances may be monitored during the season.

25.2 Young Rider Athlete Selection

At the beginning of each year / season Young Rider Athletes who wish to take part in the YR HSI programme must make themselves known to their HSI High Performance Manager, so that their performances may be monitored.

All Young Riders must meet FEI and EI MER requirements for any FEI event.

Young Riders wishing to compete abroad must have the additional MERs required for overseas events and should have competed at the level of competition for which they wish to travel.

25.3 Junior Athlete Selection

At the beginning of each year/season, Juniors must send an expression of interest to HSI for the Youth Eventing Programmes.

Junior Athletes who wish to apply to compete at any FEI event must consult with their HSI High Performance Manager prior to making their application.

To compete at International events Juniors must first meet all FEI and EI requirements and have their application approved.

A Junior Athlete wishing to compete abroad must have the additional MERs required for overseas events and should have competed at the level of competition for which they wish to travel.

As per **FEI Rule 504.2.3 Junior Championships**, once an Athlete has taken part in an Eventing Championship for Seniors or in eventing at a Regional or Olympic Games, he can no longer go back to an Eventing Junior Championship.

25.4 Pony Athlete Selection:

At the beginning of each year/season, Pony Athletes must send an expression of interest to HSI for the Youth Eventing Programmes.

Pony Athletes who wish to apply for selection at any Junior Event must make their applications through and receive the approval of their own Coach and comply with all conditions and qualifications as per above.

Pony Athletes who wish to apply to compete at any FEI event (CCI1* Intro, CCIP1 and CCIP2) must consult and have approval from the HSI High Performance Pony Manager **prior to making their application**.

To compete at International Pony Classes, Pony Athletes must first meet all FEI and EI requirements and have their application approved.

A Pony Athlete wishing to compete abroad must have the additional MERs required for overseas events and should have competed at the level of competition for which they wish to travel.

A Pony Athlete may compete in eventing competitions not limited to ponies if appropriately qualified, without losing his status as a Pony Athlete.

NOTE: Athletes of the appropriate ages may take part in competitions for Ponies, Juniors and Young Riders **but they may only compete in one of the Championships in any one calendar year**.

26 PROCEDURE FOR INTERNATIONAL APPLICATIONS

Once the International Schedules have been approved by the FEI, Eventing Ireland will open the applications online for that event. Schedules can also be found through the Horse Sport Ireland website or the FEI.

Irish Athletes wishing to compete at International Events must first be members of Eventing Ireland and their horses registered with Eventing Ireland.

Athletes must make an application to their chosen event via the Eventing Ireland website. An application fee will be charged per entry, per International event and must be made online **BY NOON THE DAY BEFORE** the event's close of entry. The application fee will automatically double after this time. If the application date is then extended by the Organiser after the initial

close of entries, any late application fees already paid will stand. Eventing Ireland is not responsible for entries to overseas international events.

Eventing Ireland Head Office will check if Athletes meet the required Minimum Eligibility Requirements (MERs). It is the Athletes or owners responsibility to check all the MER's are correct and up-to-date on the Eventing Ireland website – including any MERs obtained overseas. (Please refer to Rule 8.1 International Points and MERs Gained Overseas).

When the International Application(s) has been approved, a confirmation email will be sent and the Athlete may make their entry to the event either via the Eventing Ireland website

26.1 New HSI FEI process effective from 2026

HSI has applied a new process which affects ALL Irish FEI entries for home or overseas Internationals. Athletes are now required to register themselves and their horses via the Horse Source portal BEFORE an entry can be made to an international event.

Athletes must make their own FEI entries via Horse Source, managed by HSI. This is an **additional step** to the existing process. All Athletes are still required to make international applications via Eventing Ireland, as per Rule 26 above.

The HSI Horse Source system only adds your details to the FEI entries site, you will not have paid your entry fee to the actual event. Payment must still be made for entry fees via the Eventing Ireland website (for Irish Internationals) or the venue's website (for Overseas Internationals).

HSI have created a guide for entering details onto the system for an International via Horse Source <https://www.horsesportireland.ie/how-to-enter-via-horse-source/>. Athletes/owners are encouraged to read this information carefully, and take note of the fees for withdrawals, changes or substitutions after close of definite entries.

Horse Source and the associated fees are managed entirely by HSI, so all queries in this regard should be directed to HSI on feientries@horsesportireland.ie

FEI registrations and licenses are issued by Horse Sport Ireland – please use link: <https://www.horsesportireland.ie/team-ireland/fei-passports/>

If the Athlete needs to withdraw an approved application, they must contact Eventing Ireland Head Office and ensure they make their own withdrawal from the FEI entries system via the Horse Source portal. Please note, fees will apply if withdrawal from Horse Source takes place after close of entries.

It shall be an offence for an Irish Athlete, or any person acting on their behalf, to enter or seek to enter any FEI competition(s) without firstly going through the Eventing Ireland International Application process. Only on approval being granted may the Athlete enter the competition.

A reported breach of this rule may be considered by the Board of Eventing Ireland, which may summarily impose a fine of €100.

Declined Applications

The Athletes application will be declined if the MERs and/or ERQI rating do not meet the required criteria to compete at that desired class and/or there is no opportunity to gain MERs before the qualifying deadline.

If an Athlete has made an entry, **pending approval**, which is subsequently declined, the Athlete or their representative must notify Head Office immediately. It is mandatory that this entry is withdrawn from both the Eventing Ireland website and FEI entry system.



Application and entry refunds will be given if you do not gain your MERs. All other entry refunds are at the discretion of the **Event Organiser only** – please refer the FEI Schedule.

26.2 Senior Athlete Participation at International Events

- a) Owners and Athletes must be members of Eventing Ireland
- b) As per **FEI Rule 503.2 Age of Athletes**, an Athlete is considered a senior from the beginning of the calendar year in which he reaches the age of 18. International Competitions are limited to senior Athletes unless specifically organised for U25s, Juniors, Young Riders or Pony Riders with the following exceptions.
 - i. With the express permission of his National Federation, an Athlete may compete **in the Eventing World Breeding Championship for Young Horses (7yo) from the year in which the Athlete reaches the age of 16.**
 - ii. With the express permission of their National Federation, an Athlete may compete in a 3* Level competition from the beginning of the calendar year in which he reaches the age of 16.
 - iii. With the express permission of his National Federation, an Athlete may compete as a senior in a two star level competition from the beginning of the calendar year in which he reaches the age of 14
 - iv. With the express permission of his National Federation, an Athlete may compete in a one star level competition from the beginning of the calendar year in which he reaches the age of 12.
- c) Qualifications are as per MER Rule 30.

26.3 Young Rider Athlete Participation at International Events

- a) Owners and Athletes must be members of Eventing Ireland.
- b) As per **FEI Rule 503.1.3 Young Rider Competitions**, an Athlete may compete as a Young Rider from the beginning of the calendar year in which he reaches the age of 16 until the end of the calendar year in which he reaches the age of 21.
- c) A Junior in their 18th year may compete as a Young Rider with the agreement of both the Junior and Young Rider HSI High Performance Managers. In this situation the Junior HSI HP Manager has priority. Having chosen to be a Young Rider, the Athlete may not revert to Juniors and under FEI rules an Athlete may not compete in the Championships for different age groups in the same year.
- d) Qualifications are as per MER Rule 30.

26.4 Junior Participation at International Events

- a) Owners and Athletes must be members of Eventing Ireland
- b) As per **FEI Rule 503.1.2 Junior Competitions**, an Athlete may compete as a Junior from the beginning of the calendar year in which he reaches the age of 14 until the end of the calendar year in which he reaches the age of 18.
 - i. With the express permission of his National Federation, an Athlete may compete **in the Eventing World Breeding Championship for Young Horses (6yo) from the year in which the Athlete reaches the age of 14.**
- c) Qualifications as per MER Rule 30.

26.5 Pony Athlete Participation at International Events

- a) Owners and pony Athletes must be members of Eventing Ireland.
- b) As per **FEI Rule 503.1.1 Pony Competitions**, an Athlete may compete as a Pony Athlete from the beginning of the calendar year in which he reaches the age of 12 until the end of the year in which he reaches the age of 16.
- c) A Pony Athlete may compete in eventing competitions not limited to ponies if appropriately qualified without losing his status as a Pony Athlete.
- d) Qualifications as per MER Rule 30

27 CONDITIONS

Extract from **FEI Eventing Rules – Structure of Competition**

Article 501 Competitions and Series

501.1 International (CIs)

Competitions with an individual classification. Location, date and level of CIs must be approved by the FEI. Special requirements may apply for 4&5 star level Competitions at new venues.

At One and Two star level, competitions of the same level can be divided in several sections and be treated as a single entity according to specific provisions.

Article 502 Formats and Levels

Competitions are also defined by their format and level.

502.1 Formats

502.1.1 Definition

Formats define some of the technical aspects of the competition (duration of the competition, intensity of the cross country test, order of tests, etc.)

502.1.2 CCI-L (Long Format Competition)

A Long Format Competition may take place over three or more days. The dressage test will be spread over one or more consecutive days, depending on the number of competitors, directly followed on the next day by the cross country test that will be directly followed on the next day by the show jumping test.

In the Long Format Competitions the cross country course will be of such a length that the horse is required to be supremely fit and stamina will be required for success.

The cross country test will always take place before the show jumping test.

502.1.3 CCI-S (Short Format Competition)

A Short Format Competition may take place over one or more days. The dressage test will always take place first and will be followed on the same or following days by the show jumping and cross country test.

In the Short Format Competition the level of difficulty of the cross country course is similar to the Long Format according to the star system, but the course is shorter and the intensity of efforts will be higher.

The cross country test will always take place after the show jumping test.

Note: The cross country as last test is compulsory from 1 January 2014. Only for specific reasons and after approval by the FEI, can the show jumping could be organised as last test.

Article 502.2 Levels of difficulty

The levels indicate the degree of difficulty of the competition and are defined by a progressive star system ranging from the lower 1* level to the higher 5*.

The 5*-L level competitions require the maximum level of training and experience from both Athlete and horse.

28 ATHLETE INFORMATION

28.1 Participation Restrictions (Article 504)

Article No	Restrictions
504.1.1 Championships and Games	An Athlete may only ride one horse
504.1.2 CIOS	An Athlete may ride only one horse as a member of a team and may ride in only one team.

Article No	Restrictions
	Where an Athlete is entered with a horse in a team competition, he must always ride that horse before any additional horse he is riding in the individual competition
504.1.3 CIs	<p>There is no limitation to the number of horses an Athlete may ride in an individual competition, with the following exceptions:</p> <p>a) The Organising Committee may impose a balloting procedure, in its absolute discretion, whether for time-tabling or any other reason. Such a procedure must be published in the schedule of the competition.</p> <p>b) If a competition has more entries than it can accommodate, no Athlete may ride more than two horses (or one horse if so decided by the Organising Committee).</p> <p>National Federations are anyway responsible, in entering Athletes in International Competitions, to ensure that no Athlete rides more horses than his abilities in any one day of cross country</p>

28.2 FEI Technical Requirements For Participation

2.6.1 Both horse and Athlete must satisfy the rules for qualification at CI events as detailed in the FEI rules of Eventing.

2.6.2 Extract from the FEI Eventing Rules

Article 516 Principles

In order to be entered in an international competition Athletes and horses must first and foremost fulfill the criteria set by their National Federation.

In addition to the criteria set by National Federations the eligibility to compete will be determined by the achievement of a number of Minimum Eligibility requirements (art. 517) in International Competitions.

MERs have to be achieved by the horse or by the Athlete/horse as a combination according to the level of competence/experience (art. 519 Athletes Categories) of the Athlete and the level of the competition. National Federations are encouraged to set stronger and additional criteria to FEIs minimum requirements for horses and Athletes.

Organising Committees, with the approval of the FEI and their own National Federation, may also impose additional criteria for horses and/or Athletes, which must be published in the schedule approved by the FEI.

The Technical Delegate, or his nominee, shall check that all horses and Athletes are correctly entered by their National Federation and registered with the FEI.

Article 517 Minimum Eligibility Requirement (MER)

A Minimum Eligibility Requirement is achieved by completing a competition within minimum parameters of all round performance as follows:

- a) **Dressage Test:** Not more than 45 penalty points (or <55% dressage good marks)
- b) **Cross Country Test:**

- A clear round (0 penalties) at obstacles (activating a maximum of one frangible device or having a maximum of one missing flag will maintain the MER result on Cross Country
 - Not more than 75 seconds exceeding the optimum time in the cross country test for 1*, 2*, 3* and 4* level competitions.
- c) **Jumping Test:** Not more than 16 jumping penalties at obstacles.

NOTE: All MERs obtained in previous years will be counted according to the rules in place at that time.

Article 518 Minimum Eligibility Requirement Validity Period.

Championships:

The valid period for obtaining a Minimum Eligibility Requirement is from the preceding calendar year to the closing date of the nominated entries.

Art 5.18.2 CI's and CIOs:

The deadline for obtaining a Minimum Eligibility Requirement for CIs and CIOs is:

- a. At least 24 days before the cross country test of the competition for which it is needed if the MER has been achieved at a Long Format Competition (CCI-L).
- b. At least 10 days before the cross country test of the competition for which is needed if it has been achieved at a Short Format Competition (CCI-S)

New Art. 518.3 CCI4*-S/L and CCI5*-L additional requirements

Horses having not completed the cross country test of an FEI Competition for a period of 13 consecutive months or more will have to fulfil the below additional requirement(s) before entering a CCI4*-S/L or CCI5*-L event as follows:

Horses having obtained an MER at CCI4*S or CCI3*S/L

- To enter a CCI4*S: must complete the Cross Country test of a CCI3*S/L
- To enter a CCI4*L: must complete the Cross Country test of a CCI4*S and a CCI3*S/L

Horses having obtained an MER at CCI4*L

- To enter a CCI4*L or CCI5*L: must complete the Cross Country test of a CCI4*S

Horses having obtained an MER at CCI5*L

- to enter a CCI5*L: must complete the Cross Country test of a CCI4*S/L

** Period calculated from the date of the cross country test of the first event to the date of the cross country test of the following event.*

Article 519 Athletes Categories

FEI Athlete categories for Eventing define a recognition of proven competence of the Athlete at a certain level.

Athletes will be categorised (Uncategorised- NC, D, C, B, A) according to their performance in a rolling four years period as defined in the following table

W-CH and WG to count as 5* level MER towards Athlete categorisation

Cat	Description
D	Ten (10) MER at FEI Short (CCI-S) or Long (CCI-L) format Competitions of 2* level or above; or three (3) MER at FEI Short (CCI-S) or Long format (CCI-L) competitions at higher level.

C	Ten (10) MER at FEI Short (CCI-S) or Long (CCI-L) format Competitions of 3* level or above; or three (3) MER at FEI Short (CCI-S) or Long format (CCI-L) competitions at higher level.
B	Ten (10) MER at FEI Short (CCI-S) or Long (CCI-L) format Competitions of 4* level or above; or three (3) MER at FEI Long format (CCIs) competitions at five star level.
A	Ten (10) MERs at FEI Short (CCI-S) or Long (CCI-L) format) format Competitions of 4* level or above of which three (3) were at 5* level

The Athlete category will be updated at the end of each month (after the results for the relevant month have been processed) taking into account the rolling **four years (4)**.

The Athlete category at the closing date of definite entries prevails.

Article 520 Minimum Eligibility Requirements for CIs and CIOs

The following table details the requirements needed to be entered in the different formats, categories and levels of international competitions. NFs are required to set national participation requirements as per Art 516 to apply for all categorisations.

Exceptions for MER's:

- The first activation of a frangible/deformable device or having one missed flag will still allow an MER.
- When multiple Minimum Eligibility Requirements are required (for CIs and CIOs), one of the Minimum Eligibility Requirements (at the same level) can be achieved incurring **a maximum of 20** penalties at the obstacles of the Cross Country test. (See below for Minimum Eligibility Requirements for Championships & Games).

(Note: **Please see EI MER requirements Rule 30**)

The Minimum Eligibility Requirements must be achieved as a combination according to the following table:

CCI1*	All Athletes	NF Requirements Only
Short Format Inc MER obtained as per NF Requirements		
CCI2*-S	All Athletes	NF Requirements Only
CCI3*-S*	Uncategorised Athletes	1 CCI2*S
	D Athletes	NF Requirements Only
	C or B or A Athletes	NF Requirements Only
CCI4*-S	Uncategorised or D or C Athletes	3 CCI3*S
	B or A Athletes	1 CCI3* (Horse Only)
CCI-L Long Format Inc MER obtained as per NF Requirements		
CCI2*-L	All Athletes	NF Requirements Only
CCI3*-L	Uncategorised Athletes	2 CCI3*S and (1 CCI2*L or 1 CCI3*S)
	D Athletes	1 CCI3*S or 1 CCI2*L
	C or B or A FEI Athletes	1 CCI2*L or CCI3*S (Horse Only)
CCI4*-L	Uncategorised or D or C Athletes	2 CCI3*L and 1 CCI4*S or 1 CCI3*L and 2 CCI4*S

CCI-L Long Format Inc MER obtained as per NF Requirements		
	B or A FEI Athletes	1 CCI3*L (Horse only)
CCI5*-L	Uncategorised or D or C Athletes	2 CCI4*L and 3 CCI4*S
	B Athletes	1 CCI4*L and 3 CCI4*S
	A Athletes with horses having not yet obtained an MER at CCI5*L Competition	1 CCI4*L
	A Athletes with horses having already obtained an MER at a CCI5*L Competition	2 CCI4*S Or 1 CCI4*L

National Federations have the option to apply to use CNs (National Competitions) for qualification purposes only to replace Events cancelled due to weather conditions and/or exceptional circumstances.

Targeted CNs are those for which the FEI has received and approved a request from the relevant NF for this specific purpose. MERs obtained at the specific targeted national events will only count for upgrade and not for Athletes categorisation.

The application must be sent a minimum of 10 days before the Event. An FEI 3&4* Technical Delegate must function at the event taking responsibility for the technical standards/level of the Competition and must report to the FEI (TD report) including full results.

Article 521 Minimum Eligibility Requirements for Championships & Games

For Championships & Games, all Minimum Eligibility Requirements must be achieved as a combination and must be clear on the obstacles of the cross country test. The first activation of a frangible/deformable device (11 penalties) or having 1 Missed flag (15 penalties) will still allow a MER.

Level	Requirements
CH 2*	1 CCI2*-L
CH 3*	1 CCI3*-L
CH 4*-S	1 CCI4*-S
CH 4*-L	1 CCI4*L
W-CH	1 CCI5*-L or (1 CCI4*-L + 1 CI 4- S)

For the valid period of obtaining a MER, refer to Art 518 in the FEI Rule Book

Qualification for Young Horse Championships will be established separately by the Eventing Committee on an annual basis.

Article 522.1 Reverse Qualification - HORSE

A reverse qualification is the obligation for a horse to show restored competence at a lower level (MER) after a number of unsuccessful attempts at a certain level. Reverse qualification only applies to the horse.

A reverse qualification is triggered by:

- a) two (2) consecutive cross country eliminations **or**
- b) a total of three (3) cross country eliminations within a twelve (12) months rolling period of time in international competitions.

For this purpose the relevant reasons of elimination on cross country would be:

- a) Three (3) refusals
- b) Fall of horse or Athlete
- c) Dangerous riding
- d) Elimination by the Ground Jury

Reverse qualifications remain unless cleared by an MER at the lower level.

In the case of a reverse qualification at a certain level the horse must obtain a Minimum Eligibility Requirement in an international competition at the level below before being allowed to compete again at the original level (eg. horse with 2 eliminations at 3* level (any format) must obtain a MER at 2* level (any format) before going back to 3* level (any format))

If a reverse qualification is triggered by eliminations that occur at different levels (any format), then the horse must obtain a MER at the level below (any format) the highest level of competition at which an elimination occurred.

If a reverse qualification is triggered following eliminations at 2* level (any format) then the NF must assess the Horse at National level or at a CC11* Competition and provide a written report to the FEI Eventing Department before the Horse may again take part in any international Eventing Competition. The same principle applies to Ponies reverse qualified at CCIP2 level.

If a reverse qualification is triggered following eliminations at 1* level, then the NF must assess the Horse at a National Competition and provide a written report to the FEI Eventing Department before the Horse may again take part in any international Eventing Competition. The same principle applies to Ponies reverse qualified at CCIP1 level.

Article 522.2 Reverse Qualification – ATHLETE

In addition to the above, should an Athlete be fully involved with two (2) reverse qualifications within a twelve (12) months rolling period of time his category will drop down one (1) level for one (1) year, as of the date of the second reverse qualification.

One Cross Country elimination can trigger two reverse qualifications if it fulfils the criteria of two consecutive Cross Country eliminations and three **Cross Country eliminations** within a twelve month rolling period

28.3 Nationality of Athlete & Owner

Athletes may take part in all competitions (Championships, CCIO's, and other International Events, including Juniors, Young Riders or Seniors) except Olympic Games with horses belonging to legal owners of a different nationality (see FEI "General Regulations", Art.139).

28.4 Overseas International Entries

Only the Eventing Ireland Office may forward approved applications/entries to HSI/FEI for international competitions.

An Athlete who is an EI member and resides overseas may seek the approval of the HSI High Performance Manager to compete at an International CI Event where that Athlete meets the qualifying criteria of the national Federation of the country in which they reside (national records with full results must be submitted to the EI Office) and of the FEI and/or meet EI qualifications as well.

28.5 Nationality Status of Athletes

The National Federation of a country from which an Athlete holds his passport is his own National Federation. An Athlete who is a national / citizen of more than one nation must decide which is his own National Federation and must thereafter compete under the jurisdiction of that National Federation. Eventing Ireland may, in exceptional circumstances, approve applications for overseas Athletes resident in Ireland, but only with the express written permission from the Athletes National Federation.

29 HORSE INFORMATION

29.1 Participation of Horses

A horse must be registered with Eventing Ireland and FEI and have a valid current FEI Passport if competing outside Ireland or at a 4* event and above in Ireland.

The following minimum age of horses will apply for all competitions.

Level	Minimum Age and Restrictions
CCI1*	<p>A horse may compete in competitions of 1* level from the beginning of the calendar year in which he reaches the age of five</p> <p>A Horse that has obtained a Minimum Eligibility Requirement at a five star level competition in the current or preceding year may not be entered in a one star competition unless the Athlete is Non-Categorised</p>
CCI2*	<p>A horse may compete in competitions of 2* level from the beginning of the calendar year in which he reaches the age of six</p> <p>A Horse that has obtained a Minimum Eligibility Requirement at a five star level competition in the current or preceding year may not be entered in a one star competition unless the Athlete is Non-Categorised</p>
CCI3*	<p>A horse may compete in competitions of 3* level from the beginning of the calendar year in which he reaches the age of six</p>
CCI4*	<p>A horse may compete in competitions of 4* star level from the beginning of the calendar year in which he reaches the age of seven</p>
CCI5*	<p>A horse may compete in competitions of five star level from the beginning of the calendar year in which he reaches the age of nine</p>
Junior Championships	<p>Junior Championships are open to all horses except those which have competed in a five star competition, in a Senior Eventing Championship or in eventing at the Olympic Games during the preceding or current year.</p>

Except for Competitions limited to Ponies (CCIPs), all international Eventing Competitions are open to Horses and Ponies, provided the Ponies and their Athletes meet all relevant qualifications.

Article 503.5.2 Age of Pony

A Pony may compete in CCIP1 Pony Competitions from the beginning of the calendar year in which the Pony reaches the age of five and in CCIP2 Pony competitions from the beginning of the Calendar year in which reaches the age of six.

A pony may only compete in an FEI European Pony Championship from the beginning of the Calendar year in which it reaches the age of seven.

29.2 Participation of Ponies

A pony must be registered with Eventing Ireland and the FEI and have a current FEI Passport/ Recognition Card if competing outside Ireland. FEI ponies must be measured at an FEI Measuring session and be issued with INTERIM OR LIFETIME MEASURING CERTIFICATE in order to be allowed to take part in FEI pony competitions

A Pony may compete in International Pony Competitions from the beginning of the calendar year in which reaches the age of six.

Ponies' regulatory height at the withers must not exceed:

- 148.0cm without shoes (any measurement between 148.1cm and 148.9cm will be rounded down to 148.0cm); and
- 149.0cm with shoes (any measurement between 149.1cm and 149.9cm will be rounded down to 149.0cm).

The measuring veterinarians will put a remark in the passport: with shoes /without shoes, on the identification page.

Except for the specific competitions limited to Ponies, all International Competitions are open equally to horses and ponies, providing the ponies and their Athletes meet all relevant qualifications.

29.3 Vaccinations and Infectious Diseases at FEI Events

FEI Vaccination Rules 2026 – International Competitions Article 1002 Vaccinations and Infectious Diseases (also see the [FEI Horse App](#) which can be downloaded via the App Store)

1. All laboratory tests for infectious disease testing required by government legislation, must be recorded in the Passport.
2. All Horses entering the FEI Stables Area and/or participating in FEI Events must be vaccinated against equine influenza, according to Article 1003.
3. All Horses entering the FEI Stables Area must be FEI-registered Horses. They must comply with the equine influenza vaccination requirements as described in Article 1003, undergo an Examination on Arrival and comply with any additional health requirement.
4. Exceptions from the influenza vaccination requirements may be granted by the FEI Veterinary Department and where national legislation states otherwise which shall only be applicable to Horses competing in that nation.
5. All information concerning vaccinations must be written in the Horse's Passport in the Roman alphabet.
6. Vaccinations administered against Equine Influenza and other equine infectious diseases must be entered in the Horse's Passport on the correct vaccination page. Equine influenza vaccination details must also be recorded in the FEI HorseApp, as of 1 February 2026.
7. The name and batch number of the vaccine and the date of administration must be recorded in the Passport and in the FEI HorseApp, according to Article 1002.6. These details can be recorded in the Horse's FEI Recognition Card when the vaccination pages are full in the Horse's Passport.
8. Vaccination must be administered by a veterinarian who must sign and stamp the Passport against the relevant vaccination entry, and record the details in the FEI HorseApp, according to Article 1002.6.
9. Errors in recording vaccination details must be corrected by marking a single line through the incorrect information and re-writing all the details for that vaccination on a new line. The person marking through the incorrect information must place their initials next to the deletion. The use of correction fluid is prohibited.



10. When a new or duplicate equine Passport or FEI Recognition Card is issued, the Horse's veterinarian can use the following statement to summarise a long equine influenza history: "The vaccination history of this Horse is correct to date in accordance with the FEI Veterinary Regulations. Last vaccination on 00/00/00 date".
11. No vaccination shall be given within seven days of the Horse's arrival at the Event.
12. Vaccinations must not be given to Horses at FEI Event sites.

Article 1003 Equine Influenza Vaccination Requirements

1. All proprietary Equine Influenza vaccines are accepted by the FEI, provided the route of administration complies with the manufacturer's instructions (i.e. intramuscular injection or intranasal).
2. Any Horse that has received a Primary Course before 1 January 2024 must be vaccinated as follows:
 - a) An initial Primary Course of two vaccinations must be given; the second vaccination must be administered within 21-92 days of the first vaccination.
 - b) The first booster must be administered within 7 calendar months following the date of administration of the second vaccination of the Primary Course.
3. Any Horse receiving a Primary Course after 1 January 2024 must be vaccinated as follows:

V1 (initial vaccination);
V2 (second vaccination) must be administered 21-60 days after V1; and
V3 (first booster) must be administered within 6 months and 21 days of V2.
4. Subsequent Booster vaccinations must be administered at a maximum of 12 month intervals however Horses competing in Events must have received a booster within 6 months +21 days (and not within 7 days) before arrival at the Event.
5. Horses may compete 7 days after receiving the second vaccination of the primary course.
6. Horses that have received the Primary Course prior to 1 January 2005 are not required to fulfil the requirement for the first booster, providing there has not been an interval of more than 12 months between each of their subsequent annual booster vaccinations.

Article 1004 Prohibited Methods

1. Horses are not permitted to compete in FEI Events:
 - a) with hyposensitive or hypersensitive areas of the body;
 - b) with a tracheotomy/tracheostomy (ie. a surgical opening through the skin into the trachea);
 - c) following gene doping (ie the non-therapeutic use of cells, genes, genetic elements or the modulation of gene expression having the capacity to improve performance);
 - d) following any form of genetic modification;
 - e) following blood doping, or similar methods (eg. ozone haemotherapy),
 - f) with any object that punctures the skin with the exception of wound closure materials;
 - g) wearing contact lenses unless permission has been granted from the FEI Veterinary Department; and
 - h) if the hair on their limbs has been clipped and/or shaven at any point during the Period of the Event. Permission must be granted from the VC/VD by the PTV for clipping and/or shaving required for veterinary purposes, prior to any investigation or



treatment taking place. Horses' limbs may be clipped up to 3 days before the Period of the Event using a blade that cuts the hairs no shorter than 2mm

2. Horses are not permitted to compete if they have received any prohibited treatments in accordance with Article 1061.
3. Horses are not permitted to compete if they have received any prohibited supportive therapies in accordance with Article 1065.

Eventing Ireland and the FEI have approved sanctions of passport irregularities. Fines will be imposed by Eventing Ireland and the FEI. FEI fines are listed in the current FEI Rule Book. Please refer to the FEI Eventing Rules [HERE](#)

30 EVENTING IRELAND MERs

Eventing Ireland Minimum Eligibility Requirements (MER) to compete at an International Competition

Please note the following, which applies to all levels, including Pony Athletes:

- All results to count must be with an EI MER
- At least one MER, for all CCI1*, C12* and C13* classes, for FEI A, B, C and D Categorised Athletes must have been achieved WITHIN THE PREVIOUS 12 MONTHS of the closing date of the nominated entries for the FEI event.
- At least one MER For Non-Categorised Athletes (NC) must have been achieved within 6 months to the closing date of the nominated entries for the FEI event. This MER MUST be as a combination.
- Any Athlete and horse combination who are qualified to compete at C14* or C15* level but who have not obtained an FEI MER within 13 months prior to the close of entries of an FEI event may compete in any C12* or C13* competition. See **New Art. 518.3 CCI4*-S/L and CCI5*-L additional requirements below:**

Horses having not completed the cross country test of an FEI Competition for a period of 13 consecutive months or more will have to complete an Event at a lower level before entering a CCI4*-S/L or CCI5*-L Event as follows:

Horses having obtained an MER at CCI4*S or CCI3*S/L

- To enter a CCI4*S: must complete the Cross Country test of a CCI3*S/L

Horses having obtained an MER at CCI4*L

- To enter a CCI4*L or CCI5*L: must complete the Cross Country test of a CCI4*S

Horses having obtained an MER at CCI5*L

- to enter a CCI5*L: must complete the Cross Country test of a CCI4*S/L

** Period calculated from the date of the cross country test of the first event to the date of the cross country test of the following event.*

- All MERs obtained in the previous 4 years will be counted according to the FEI rules in place at that time.
- It is recommended that the ERQI 2.0 Rating for the combination should be AMBER OR GREEN for international competition as of the date of close of entries as printed in the FEI Schedule. The ERQI 2.0 Rating to enter any International Class may not be red for any Athlete.
- Attainment of these MER's does not certify that either a Horse or a Competitor is necessarily fit or competent to compete at the relevant level. The MER's merely indicate that levels which must have been achieved. An MER can be gained while competing HC in any Class.

Note: The deadline for obtaining an Eventing Ireland Minimum Eligibility Requirement (an **EI MER**) for any CI event, is **at least 5 days before the cross country test of the competition for which it is needed.**

Art 5.18.2 CI's and CIOs:

The deadline for obtaining an FEI Minimum Eligibility Requirement for CIs and CIOs is:

- a. At least 24 days before the cross country test of the competition for which it is needed if the MER has been achieved at a Long Format Competition (CCI-L).
- b. At least 10 days before the cross country test of the competition for which is needed if it has been achieved at a Short Format Competition (CCI-S)

FEI Athlete Categories:

Athletes should refer to the FEI Web Site for their Athlete Categorisation <https://data.fei.org/Person/EventingCategories>. FEI Athlete Categories are updated at the start of each month. The FEI Athlete Category at the closing date of definite entries prevails.

30.1 Eventing Ireland MERs for Horses and Athletes

NOTE: ALL EI National results must be clear x-country jumping penalties to meet an EI MER. The first activation of a frangible /deformable device (11 penalties) or a maximum of one missing flag (15 penalties) will still allow a MER.

ALL CI results at 1*, 2* and 3* level must be clear of cross country jumping penalties to meet EI requirements for qualification. The first activation of a frangible /deformable device (11 penalties) will still allow a MER.

Explanation of abbreviations	
CCI-S	One Day International
CCI-L	Three Day International
CI	Either a One Day or a Three Day International

MERS in **BLUE** are **EI MERS** and can be obtained as a combination or separately **unless otherwise stated**

MERS in **GREEN** are **FEI MERS** and must be obtained as a combination, unless the Athlete is already categorised at a particular level.

LEVEL	ATHLETE TYPE	Minimum MERs	FEI QUALIFICATIONS <small>Must be obtained as a combination, unless the Athlete is already categorised at a particular level.</small>		EVENTING IRELAND MERs <small>Can be obtained as a combination or separately unless stated</small>
CCI1* COMPETITIONS					
CCI1* Note: SJ: 110cm XC: 105cm	A, B, C FEI Athletes				2 x EI100
	D FEI Athletes	1 MER as a combination			3 x EI100
	Uncategorised Athletes	3 MERs as a combination			2 x EI100 or EI105 and 1 x EI110
CCI-S COMPETITIONS					
CCI2*-S In Ireland	A, B, C FEI Athletes				2 x EI110
	D FEI Athletes	1 MER as a combination			3 x EI110
	Uncategorised Athletes	3 MERs as a combination			3 x EI110
CCI2*-S Outside Ireland	A, B, C FEI Athletes				2 x EI110
	D FEI Athletes	2 MERs as a combination			4 x EI110
	Uncategorised Athletes	3 MERs as a combination			4 x EI110
CCI3*-S	A, B, C FEI Athletes				1 x EI115
	D FEI Athletes	1 MER as a combination			2 x EI115
	Uncategorised Athletes	3 MERs as a combination	1 x CCI2*S	PLUS	2 x EI115
	A & B FEI Athletes	2 MERs	1 x CCI3* (Horse Only)	PLUS	1 x CCI3*S OR 1 x EI120

LEVEL	ATHLETE TYPE	Minimum MERs	FEI QUALIFICATIONS <small>Must be obtained as a combination, unless the Athlete is already categorised at a particular level.</small>		EVENTING IRELAND MERs <small>Can be obtained as a combination or separately unless stated</small>
CCI4*-S	C & D FEI Athletes and Uncategorized Athletes	4 MERs	3 x CCI3*S	PLUS	1 x CCI3*S OR 1 x EI120
CCI-L COMPETITIONS					
CCI2*-L In Ireland	A, B, C FEI Athletes				4 x EI110 OR (2 x EI110 AND 1 x CCI2*S)
	D FEI Athletes	2 MERs as a combination			5 x EI110 OR (3 x EI110 AND 1 x CCI2*S)
	Uncategorised Athletes	3 MERs as a combination			5 x EI110 OR (3 x EI110 AND 1 x CCI2*S)
CCI2*-L Outside Ireland	A, B, C FEI Athletes				4 x EI110 OR (2 x EI110 AND 1 x CCI2*S)
	D FEI Athletes	3 MERs as a combination			6 x EI110 OR (4 x EI110 AND 1 x CCI2*S)
	Uncategorised Athletes	4 MERs as a combination			6 x EI110 OR (4 x EI110 AND 1 x CCI2*S)
	A, B, C FEI Athletes	2 MERs	1 x CCI2*-L OR 1 x CCI3*- S (Horse Only)	PLUS	1x CCI3*S OR (2 x EI115)

LEVEL	ATHLETE TYPE	Minimum MERs	FEI QUALIFICATIONS <small>Must be obtained as a combination, unless the Athlete is already categorised at a particular level.</small>		EVENTING IRELAND MERs <small>Can be obtained as a combination or separately unless stated</small>
CCI3*-L	D FEI Athletes	2 MERs	1 x CCI2*L OR 1 x CCI3*S	PLUS	1 x CCI3*S OR (2 x EI115)
	Uncategorised Athletes	4 MERs	2 x CCI3*S PLUS (1 CCI2*-L or 1 CCI3*-S)	PLUS	1 x CCI3*S OR (2 x EI115)
CCI4*-L	A & B FEI Athletes	2 MERs	1 x CCI3*L (Horse Only)	PLUS	1 x CCI4*S OR (2 x EI120)
	C & D FEI Athletes	4 MERs	2 x CCI3*L PLUS 1 x CCI4*-S OR 1 x CCI3*L AND 2 x CCI4*S	PLUS	1 x CCI4*S OR (1 x EI120)
	Uncategorised Athletes	5 MERs	2 x CCI3*L PLUS 1 x CCI4*-S OR 1 x CCI3*L AND 2 x CCI4*S	PLUS	1 x CCI4*S AND 1 x EI120 OR (2 x EI120)
CCI5*-L	A FEI Athletes with Horses NOT having obtained an MER at a CCI5*-L competition	3 MERs	1 x CCI4*L (as a combination)	PLUS	1 x CCI4*S PLUS (1 x CCI4*S OR 1 x EI120)
	A FEI Athletes with Horses having already obtained an MER at a CCI5*-L competition	4 MERs	2 x CCI4*S (as a combination) or 1 x CCI4*-L (as a combination)	PLUS	1 x CCI4*S PLUS (1 x CCI4*S OR 1 x EI120)
	B FEI Athletes	5 MERs	1 x CCI4*L PLUS 3 x CCI4*S	PLUS	1 x CCI4*S OR (1 x EI120)
	Uncategorised D or C Athletes	6 MERs	2 x CCI4*L PLUS 3 x CCI4*S	PLUS	1 x CCI4*S OR (1 x EI120)

30.2 Eventing Ireland MERs for Ponies and Pony Athletes

Eventing Ireland Minimum Eligibility Requirements (MER) for ponies and pony Athletes to compete at an International Competition. See Rule 30 above for full criteria.

All international results at pony levels CCIP1 & CCIP2 must be clear of cross country jumping penalties to meet EI requirements for qualification. **NB: A CCI2*-L for Ponies Class requires higher qualifications than a CCIP2**

It is the responsibility of the parent/guardian that All pony Athletes MUST get permission from the HSI HP Pony Manager before entering an international competition as per Rule 25.4

PONY ATHLETES			
COMPETITION TYPE	LEVEL (Notes)	Notes	EVENTING IRELAND PONY MERs
CCIP1	Intro	Age: 12 th year SJ: 105cm XC: 100cm	3 MERs must be as a combination 3 x EI100
CCIP2	Pony 2 level In Ireland	Age: 12 th year SJ: 110cm XC: 105cm	3 MERs must be as a combination 2 x EI100P or EI105 and 1 x EI110P
	Pony 2 Level Outside Ireland	Age: 12 th year SJ: 110cm XC: 105cm	3 MERs must be as a combination 2 x EI100P or EI105 and 1 x EI110P
CCI1*	Intro	Age: 12 th year SJ: 110cm XC: 105cm	3 MERs must be as a combination 2 x EI100 or EI105 and 1 x EI110
CCI2*-L (for Ponies)	2* In Ireland	Age: 14 th year SJ: 110cm XC: 110CM	3 MERs must be as a combination 5 x EI110P OR (3 x EI110P AND 1 x CCI2*-S)
	2* Outside Ireland	Age: 14 th year SJ: 110cm XC: 110CM	4 MERs must be as a combination 6 x EI110P OR (4 x EI110P AND 1 x CCI2*-S)
CCI2*-L (Senior Class)	2* In Ireland	Age: 14 th year SJ: 110cm XC: 110CM	3 MERs must be as a combination 5 x EI110P OR (3 x EI110P AND 1 x CCI2*-S)
	2* Outside Ireland	Age: 14 th year SJ: 110cm XC: 110CM	4 MERs must be as a combination 6 x EI110P OR (4 x EI110P AND 1 x CCI2*-S)
CCI2*-S (for Ponies)	2* In Ireland	Age: 14 th year SJ: 110cm XC: 110CM	2 MERs must be as a combination 3 x EI110P
	2* Outside Ireland	Age: 14 th year SJ: 110cm XC: 110CM	3 MERs must be as a combination 4 x EI110P
CCI2*-S (Senior Class)	2* In Ireland	Age: 14 th year SJ: 110cm XC: 110CM	3 MERs must be as a combination 3 x EI110P
	2* Outside Ireland	Age: 14 th year SJ: 110cm XC: 110CM	3 MERs must be as a combination 4 x EI110P

APPENDIX A: Plan of 20m x 40m Dressage Arena

Plan of 20m x 40m arena

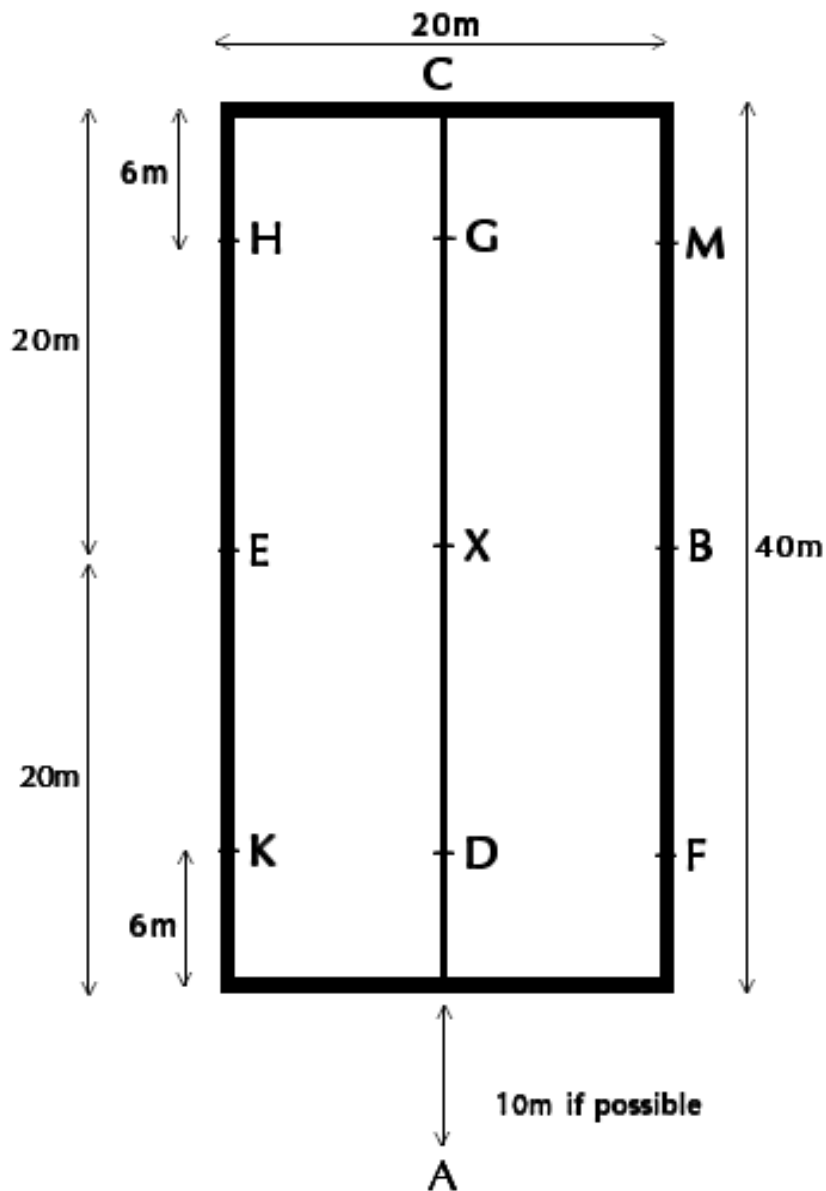

The length of the diagonal from corner to corner is 44.72m

APPENDIX B: Plan of 20m x 60m Dressage Arena

Plan of 20m x 60m arena

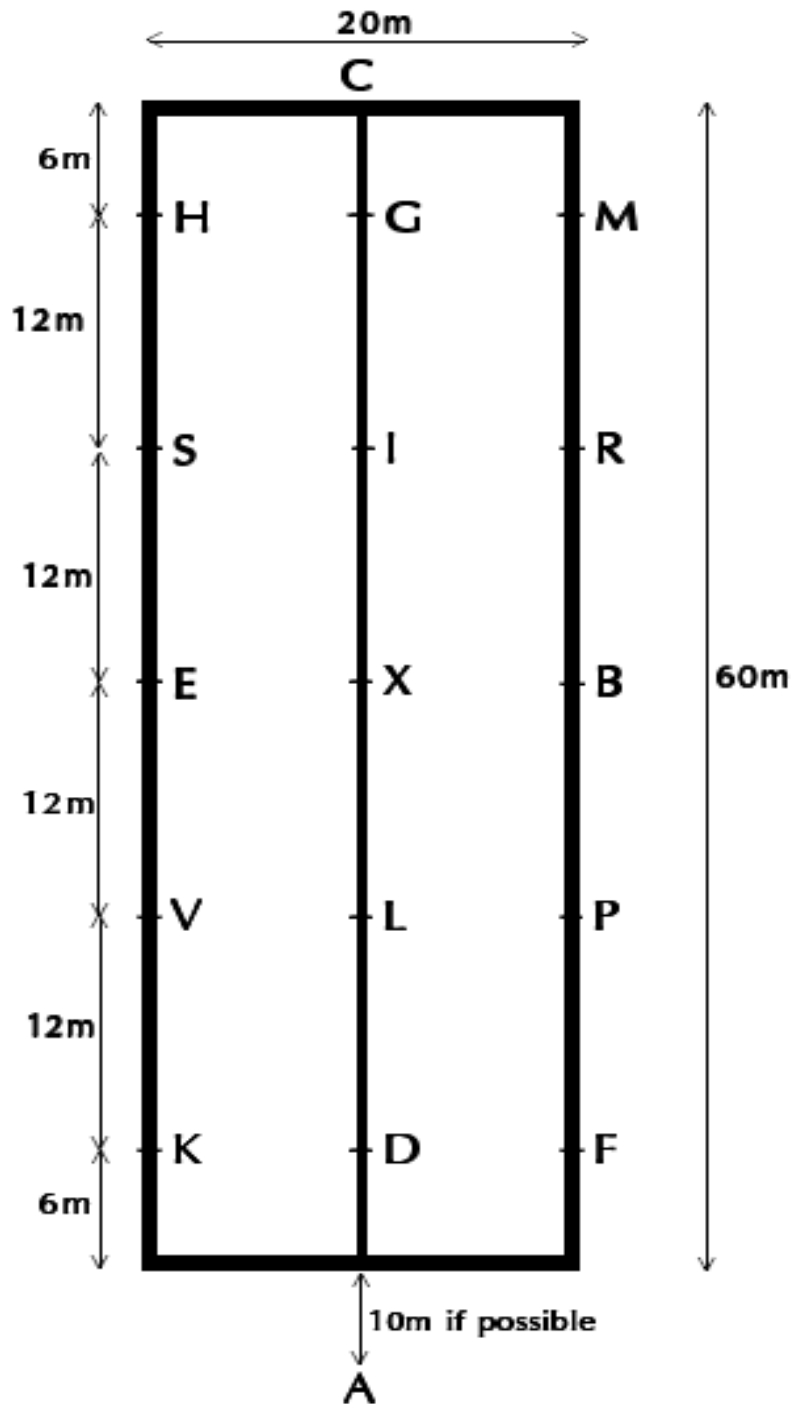

The length of the diagonal from corner to corner is 63.25m

APPENDIX C & D: Guidelines on Use of Tack

The FEI Guidelines on Tack (effective from 1 January 2026) can be found [HERE](#)

Permitted Bits for the Dressage Test

The Eventing Rules are lined up with the FEI Dressage Rules exclusively and the only exceptions are **as follows**:

- a) Young horses biting requirements of Dressage do not apply to Eventing
- b) Allowance is made for sheepskin disc for a crossed noseband and use of breastplate

Please note the following:

- a) Wavy bits are allowed
- b) Lunging reins only approved if on triangle rein (Dressage Rules the lungy-bungie is not allowed)

For Cross Country, hackamores must be used with a bit. The maximum length of the shank is 24cm, measured in a straight line from the middle of the higher ring to the middle of the lower ring.

For Cross Country, bits with a lever arm may not exceed 10cm. The length of the lever arm is measured in a straight line from the highest point where the bit is stopped to the lowest point of the lever arm.

PONIES - Clarification on Bits for All Phases**Dressage Test:**

Hackamore, curb and double bridle are not allowed.

Cross-country and Jumping Tests:

Curb, double bridles, hackamores and bitless bridles are not allowed.

(See reference in FAQ Tack, Equipment and Dress on Eventing Rules page published on the **FEI Website**)

- a) A Pelham is allowed for XC and Jumping.
- b) A Pelham is not considered a Curb bit if it has a mouthpiece ring and a ring at the top and bottom of the bit.
- c) A Pelham must be on a single rein (with a connecting piece from the mouthpiece ring to the bottom ring) – double reins not allowed.
- d) A Pelham can be used with curb chain or leather strap.

Various double bridle bits

Note: For Eventing, the bits permitted for the Dressage test have been reformulated to take into account the wide use of snaffles in Eventing (different to the Dressage Rules) as well as defining the action.

Any approved mouthpiece may be combined with any approved cheek piece.

30.2 Action of Bits

- a) Snaffle bits work on the corners, tongue and bars of the mouth depending on their shape and the rein effect produced by the Athlete
- b) Single jointed bits may also work on the roof of the mouth if not fitted and used correctly.
- c) Straight bar snaffles cause more tongue pressure

- d) Double jointed snaffles conform to the shape of the mouth and tongue creating more even pressure
- e) Rounded or moving centrepieces encourage movement of the tongue and salivation
- f) Curved mouthpieces with joints and Mullen mouth bits conform to the shape of the tongue and mouth.
- g) Cheek Pieces
- h) Full cheek, egg butt and D ring snaffles are more stable and also work on the sides of the mouth
- i) Loose ring snaffles have a more moveable mouthpiece to encourage mouthing of the bit and salivation
- j) Hanging cheek snaffles have a slight leverage action and work more on the corners of the mouth and poll. The maximum length of the cheek piece of a hanging cheek snaffle is 7cm measured from the top of the mouthpiece to the top of the small ring

30.3 Material:

- a) Durable enough to be safe
- b) Must keep smooth and solid surface, not to be altered by the chewing of the horse in order to prevent horse from injuries
- c) Not health-damaging
- d) Snaffles: can be made of metal, flexible rubber or synthetic, or plastic or leather material, and may be covered with rubber/latex.
- e) Bridoon and curb: must be made of metal and/or rigid plastic and may be covered with rubber/latex.











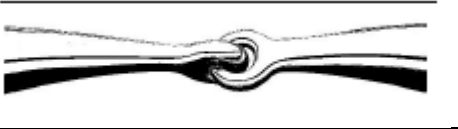
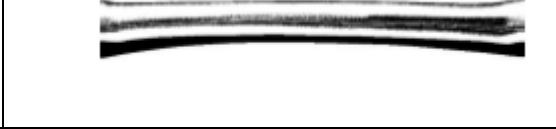
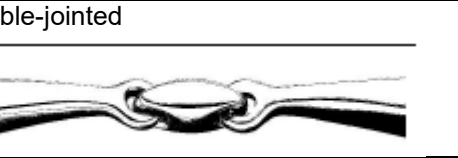

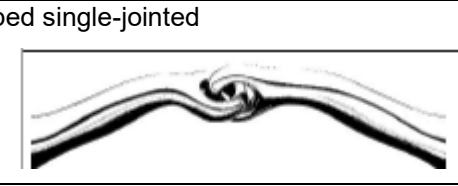
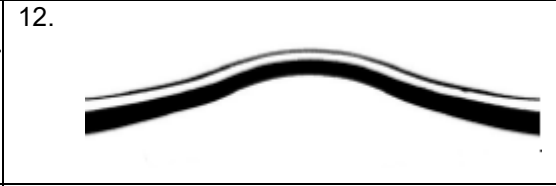
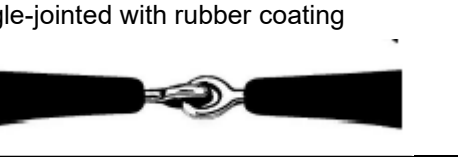
30.4 Permitted Snaffles (see diagrams)

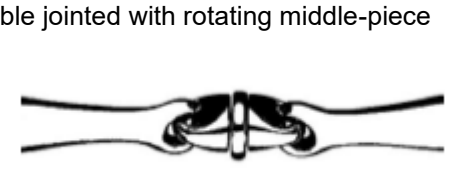
- a) May have one or two joints
- b) May be double-jointed with rounded or rotating mouthpiece allowing for better fit and comfort.
- c) May have a slightly curved port, allowing more room for the tongue. The maximum height is 30mm from the lower part of the side of the tongue to the highest point of the deviation.
- d) Wavy bits are allowed
- e) A coupling is permitted as the centre link and must be solid with no moveable parts other than a roller.
- f) The centre link must be rounded
- g) The diameter of the mouthpiece **must be a minimum of 12mm for Horses** and 10mm for Ponies at the rings or cheeks.

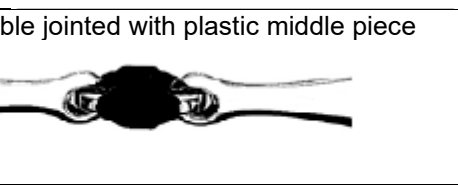

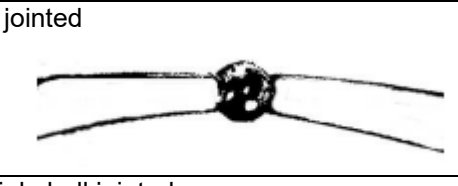

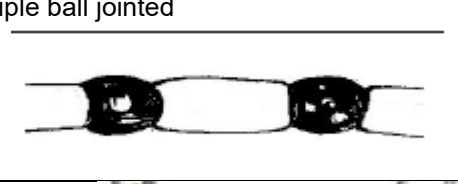

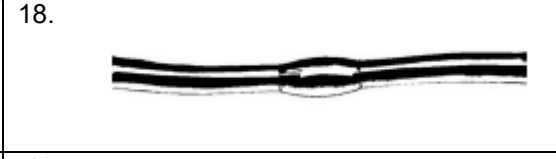
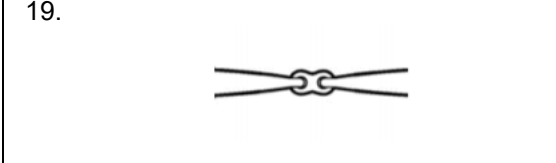



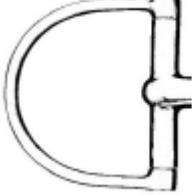

30.5 Illegal Bits







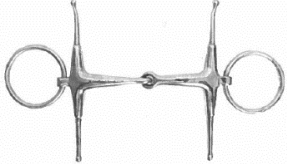

- a) Snaffles with a control plate (ie: Dr Bristol: if put incorrectly the edge of the plate causes excess pressure on tongue).
- b) Any single or double jointed cable bits (may cause pinching of the tongue or cheeks)
- c) Bits which place mechanical restraint on tongue (large immovable centre link causes excessive pressure on tongue)
- d) Bits that can slide vertically creating a gag effect
- e) Mouthpiece wings that restrict the reins to move freely.
- f) Bomber Blue Swivel bits are not permitted for Dressage.

30.6 Snaffles - Permitted Mouthpieces

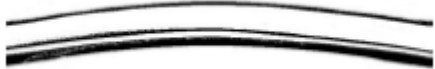



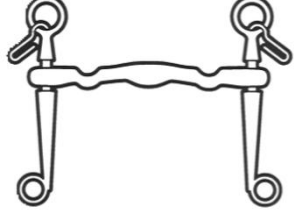

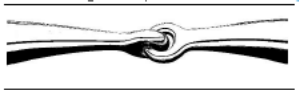

<p>1. single-jointed</p> 	<p>10.</p> 
<p>2. double-jointed</p> 	<p>11.</p> 
<p>3. shaped single-jointed</p> 	<p>12.</p> 
<p>4. single-jointed with rubber coating</p> 	<p>13.</p> 
<p>5. double jointed with rotating middle-piece</p> 	<p>14.</p> 
<p>6. double jointed with plastic middle piece</p> 	<p>15.</p> 
<p>7. ball jointed</p> 	<p>16.</p> 
<p>8. multiple ball jointed</p> 	<p>17.</p> 
<p>9. shaped double jointed</p> 	<p>18.</p> 
	<p>19.</p> 

30.7 Permitted Cheek pieces:





1. Loose Ring 	7. D-Ring 
2. Egg-Butt 	8. D-Ring 
3. Egg-Butt 	9. Loose ring with sleeves 
4. D-Ring 	10. Snaffle with full cheeks 
5. D-Ring 	11. Snaffle with full cheeks 
6. Hanging-cheek 	12. Traditional snaffle cheek piece 
	1. Hanging Cheek Not Permitted 

Permitted Curb Mouthpieces:	Permitted Curb Cheekpieces:
1. 	1. Straight cheek 
2. 	2. Straight cheek 
3. 	3. S-Shape cheek 
4. 	4. Sliding Cheek Curb 
5. 	

Permitted Mouthpieces for Bridoon

<p>1. Single jointed</p> 	<p>6. Double jointed with plastic middle piece</p> 
<p>2. Double jointed</p> 	<p>7. Ball-jointed</p> 
<p>3. Shaped single jointed</p> 	<p>8. Multiple ball-jointed</p> 
<p>4. Single jointed with rubber coating</p> 	<p>9. Shaped double jointed</p> 
<p>5. Double jointed with rotating middle piece</p> 	

Permitted Cheekpieces for Bridoon

<p>1. Loose Ring</p> 	<p>3. Egg butt</p> 
<p>2. Egg-Butt</p> 	<p>9. Loose ring with sleeves</p> 

APPENDIX E: Permitted Reins for Lungeing and Permitted Nosebands

Permitted Side/Running Reins

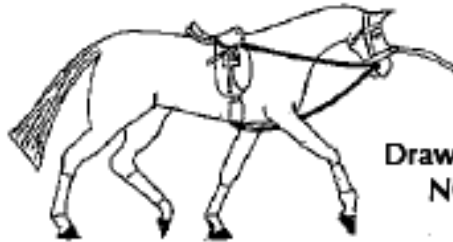

**Draw Reins for Lungeing
NOT PERMITTED**

**Running Reins for Lungeing
PERMITTED**

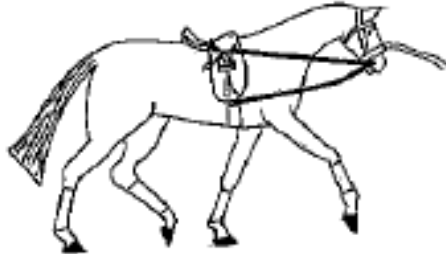

**Side Reins for Lungeing
PERMITTED**

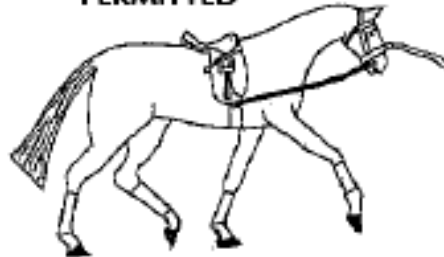

NOSEBANDS

The images below are examples only, and similar bridles which produce the same effect on the horse are also allowed if they adhere to Article 539.

1) Cavesson



2) Crossed noseband

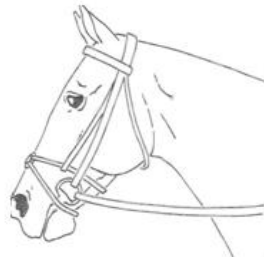

3) Dropped noseband

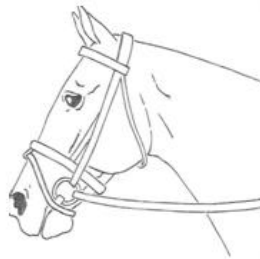

4) Flash noseband

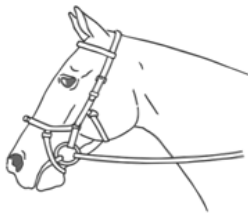

5) Micklem Bridle

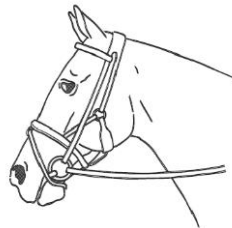

6) Stotztem (combined noseband – no throat lash)

Nosebands 2, 3, 4, 5 and 6 are not permitted when a double bridle is used

All Nosebands must be correctly fitted, and cannot be so tight to cause unnecessary discomfort to the Horse. Article 1044.8 of the FEI Veterinary Regulations applies in relation to the permitted tightness of the noseband as follows:

Effective 1 May 2026, the following provisions apply regarding the Noseband Tightness: The noseband must be adjusted with sufficient laxity, as determined by an FEI approved Measuring Device. The rule applies to all types of nosebands and to both the upper and lower noseband.

The detailed protocol for measuring the tightness of noseband(s) is provided for in the (Discipline specific) Noseband Tightness Measuring Protocol(s).

Excessively tightened noseband(s), as determined by an FEI approved Measuring Device, shall incur the following consequences:

Pre-Competition: The Horse and the Athlete combination is not allowed to start unless the noseband is re-adjusted to allow enough laxity.

During the Competition: The Horse and Athlete combination is eliminated from the Competition in question and the Athlete is issued with a Yellow Warning Card.

APPENDIX F: Cross Country Obstacles

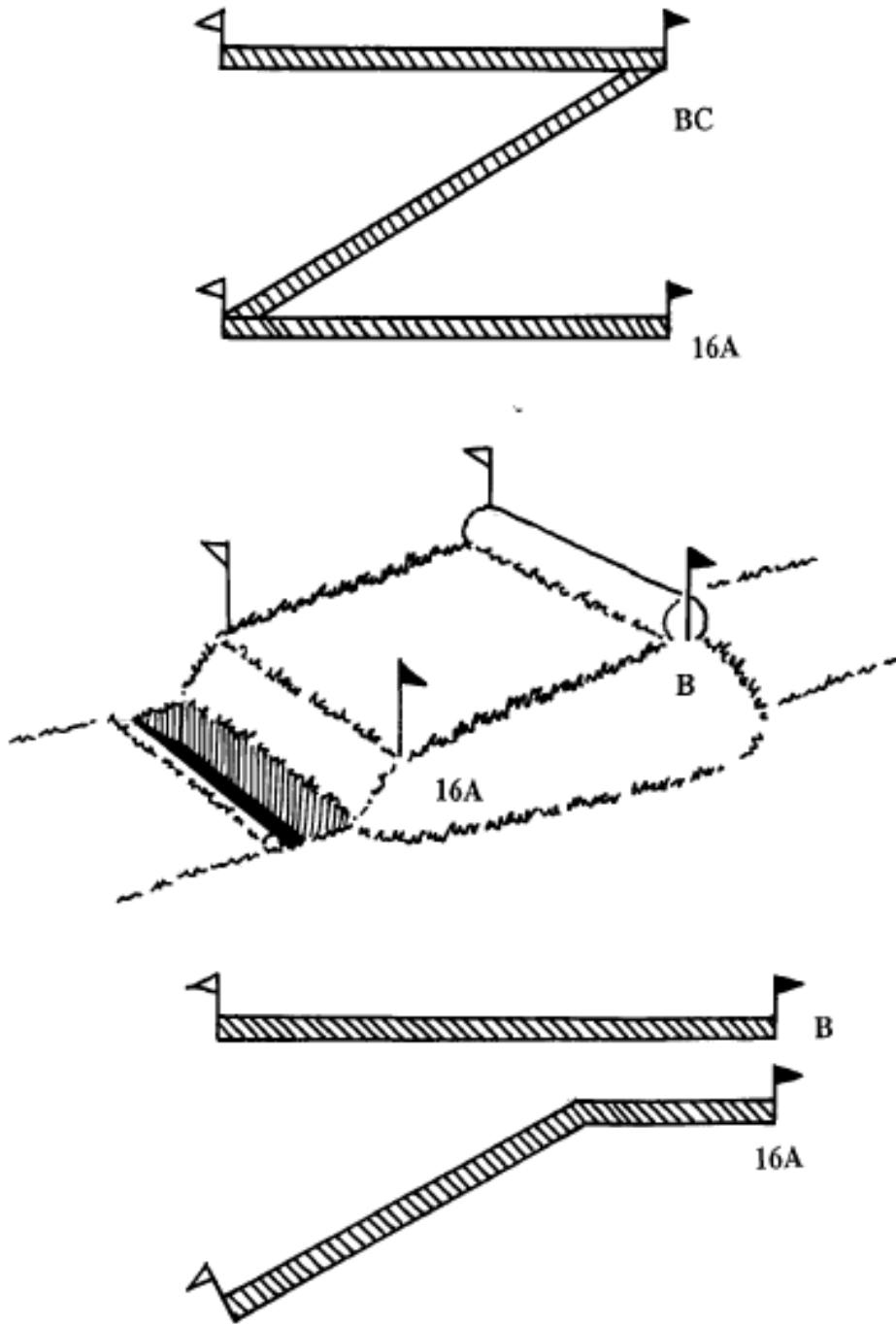

APPENDIX G: Measuring Cross Country Obstacles

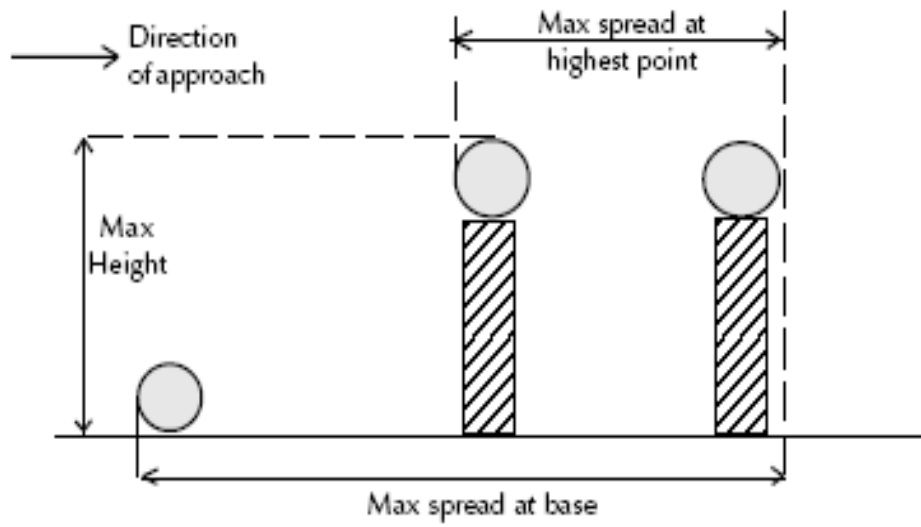

APPENDIX H: Diagrams of Cross Country Obstacles and Faults

Please refer to the Eventing Ireland website under downloads or the FEI website for the Diagrams for Cross Country Obstacles and Faults.

https://inside.fei.org/sites/default/files/2018%20Diagrams%20of%20Cross%20Country%20Obstacles_April%202021.pdf

The following diagrams are non-exhaustive examples for reference only and the respective rules will prevail.

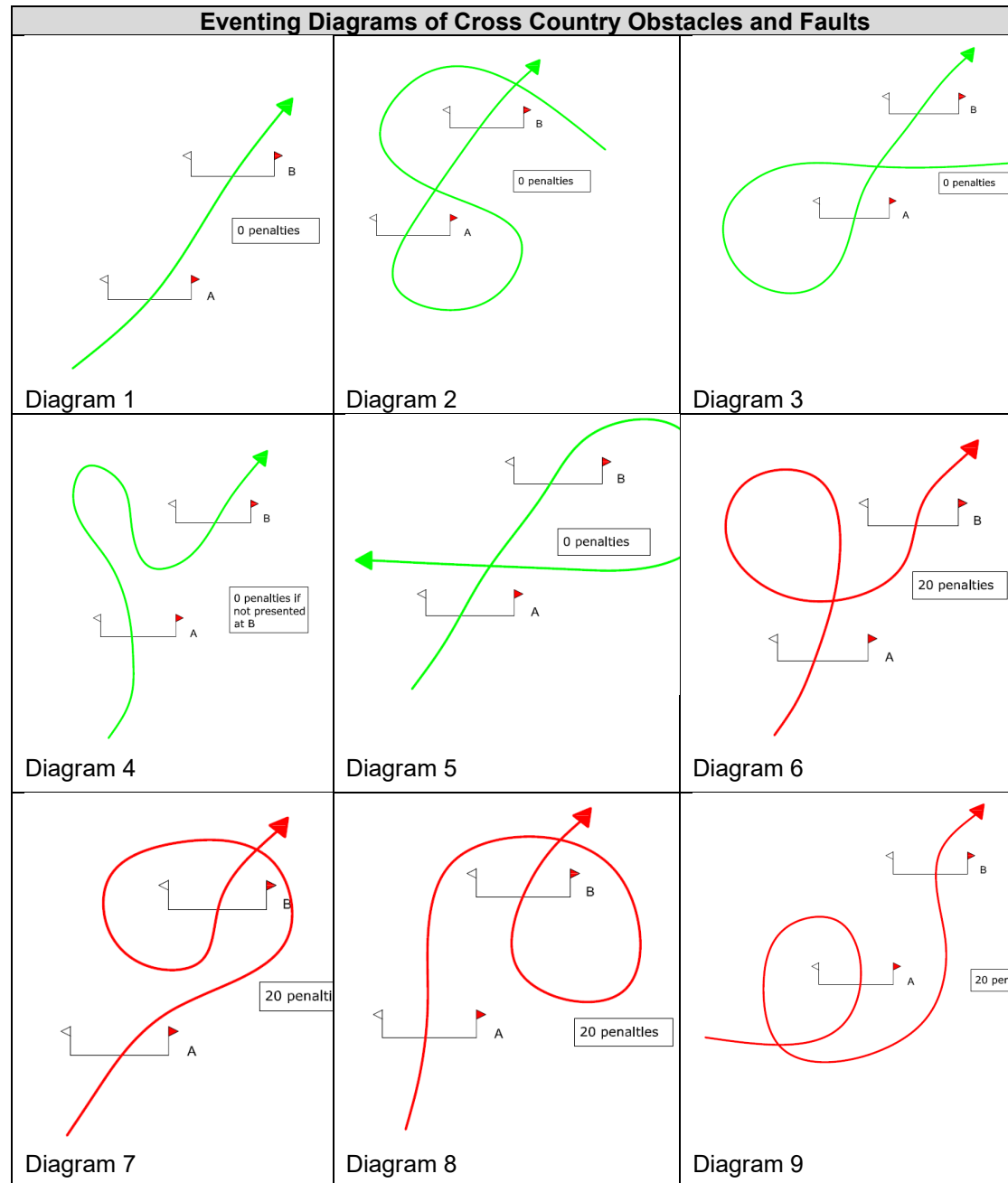

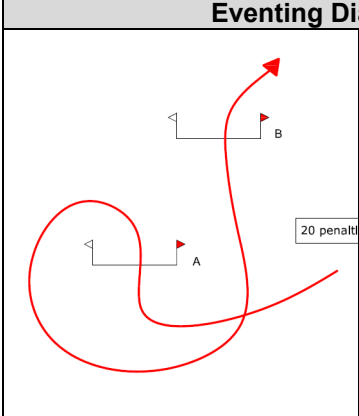
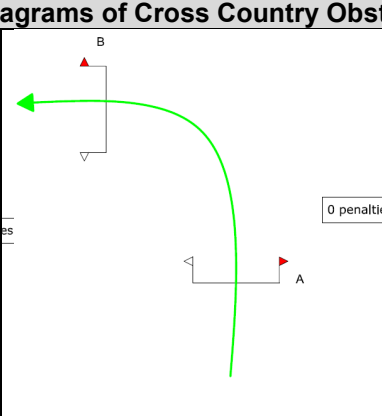
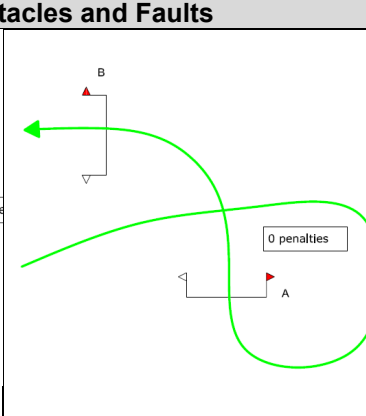
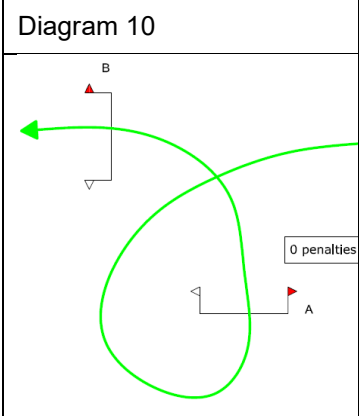
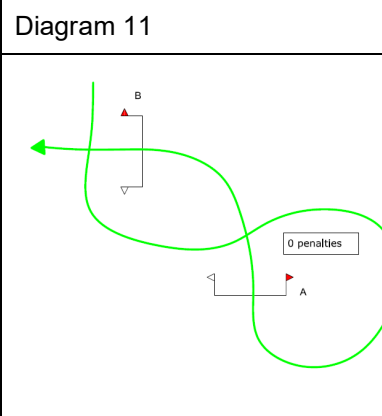
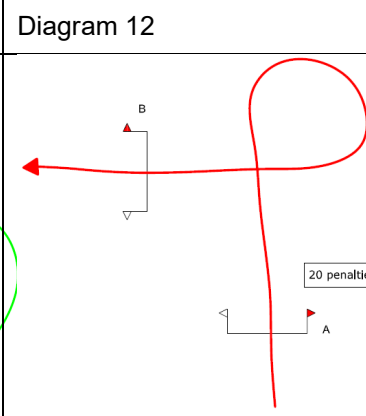
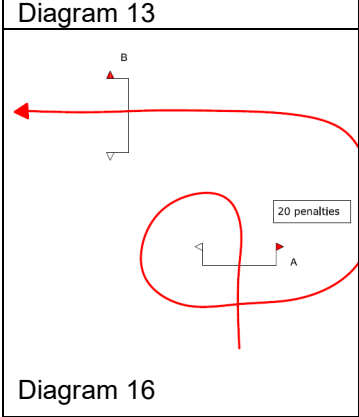
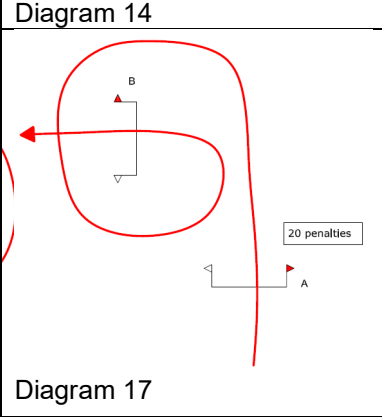
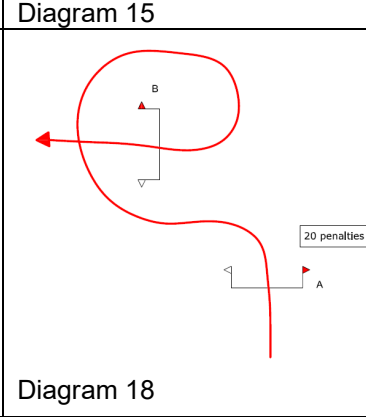
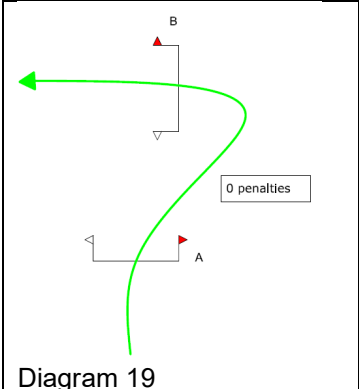
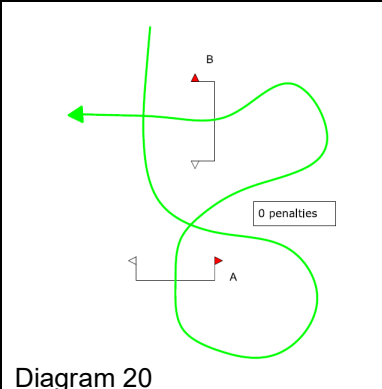
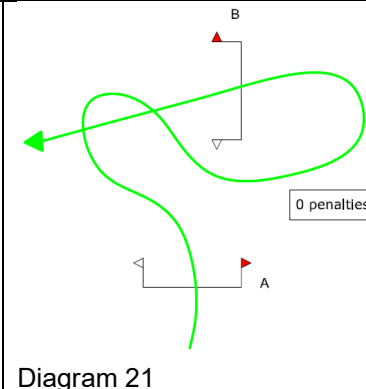
Eventing Diagrams of Cross Country Obstacles and Faults		
 <p>Diagram 10</p>	 <p>Diagram 11</p>	 <p>Diagram 12</p>
 <p>Diagram 13</p>	 <p>Diagram 14</p>	 <p>Diagram 15</p>
 <p>Diagram 16</p>	 <p>Diagram 17</p>	 <p>Diagram 18</p>
 <p>Diagram 19</p>	 <p>Diagram 20</p>	 <p>Diagram 21</p>

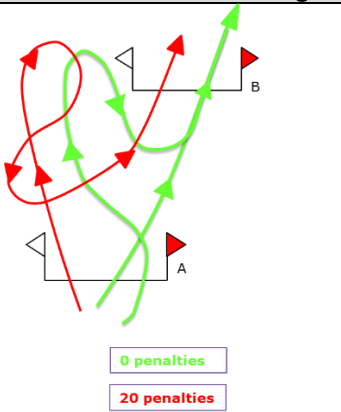
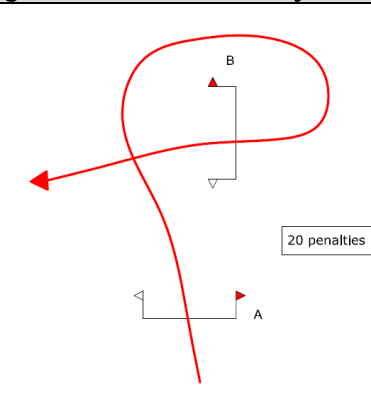
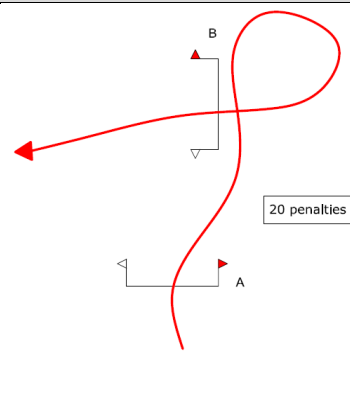
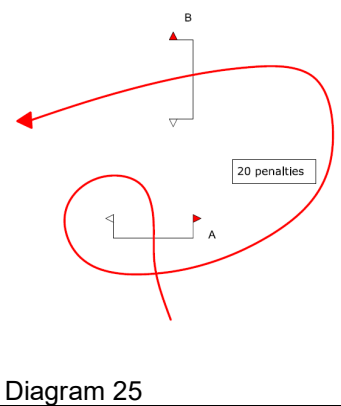
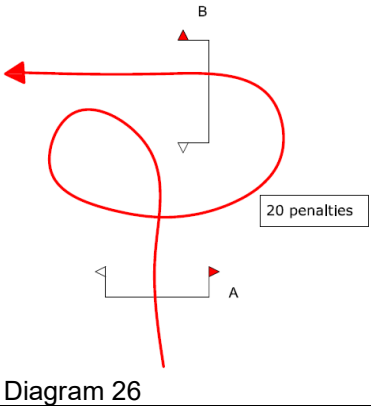
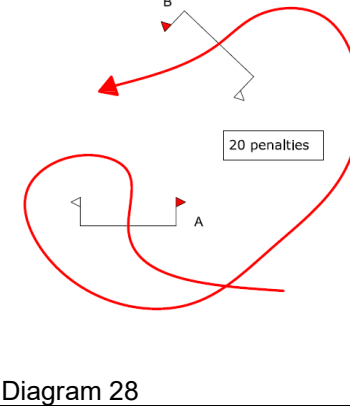
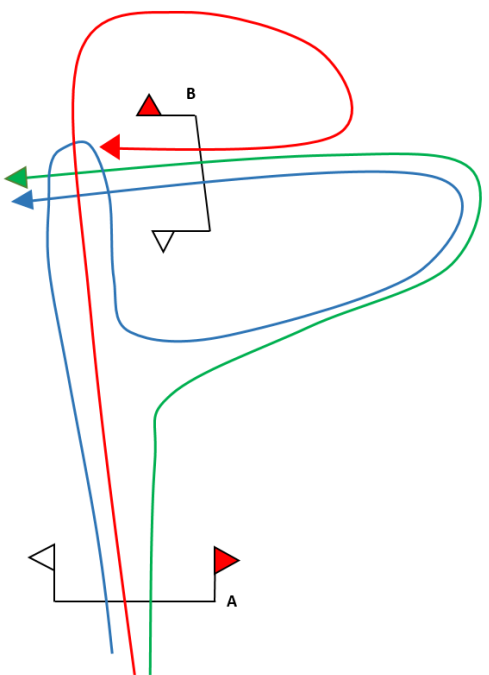
Eventing Diagrams of Cross Country Obstacles and Faults		
 <p style="text-align: center;">0 penalties 20 penalties</p>	 <p style="text-align: center;">20 penalties</p>	 <p style="text-align: center;">20 penalties</p>
Diagram 22	Diagram 23	Diagram 24
 <p style="text-align: center;">20 penalties</p>	 <p style="text-align: center;">20 penalties</p>	 <p style="text-align: center;">20 penalties</p>
Diagram 25	Diagram 26	Diagram 28
<p>At an obstacle composed of several elements (A, B, C etc) a Horse will be penalised if it passes around the back of any element or circles between elements.</p> <div style="display: flex; align-items: flex-start;"> <div style="flex: 1;">  <div style="margin-top: 10px; display: flex; justify-content: space-around;"> <div style="border: 1px solid black; padding: 2px;">20 penalties</div> <div style="border: 1px solid black; padding: 2px;">0 penalties</div> <div style="border: 1px solid black; padding: 2px;">0 penalties</div> </div> </div> <div style="flex: 2; padding-left: 20px;"> <p>Red route: 20 penalties because it passes around the back of element B (crosses the entire projection of the back of element B)</p> <p>Green route: Clear because it avoids passing around the back of element B (avoid to cross the entire projection of element B)</p> <p>Blue route: Clear because it avoids passing around the back of element B (crosses the entire projection of the back of element B but crosses back to avoid passing around the back of element B)</p> </div> </div>		
Diagram 27 and 29 (updated April 21)		

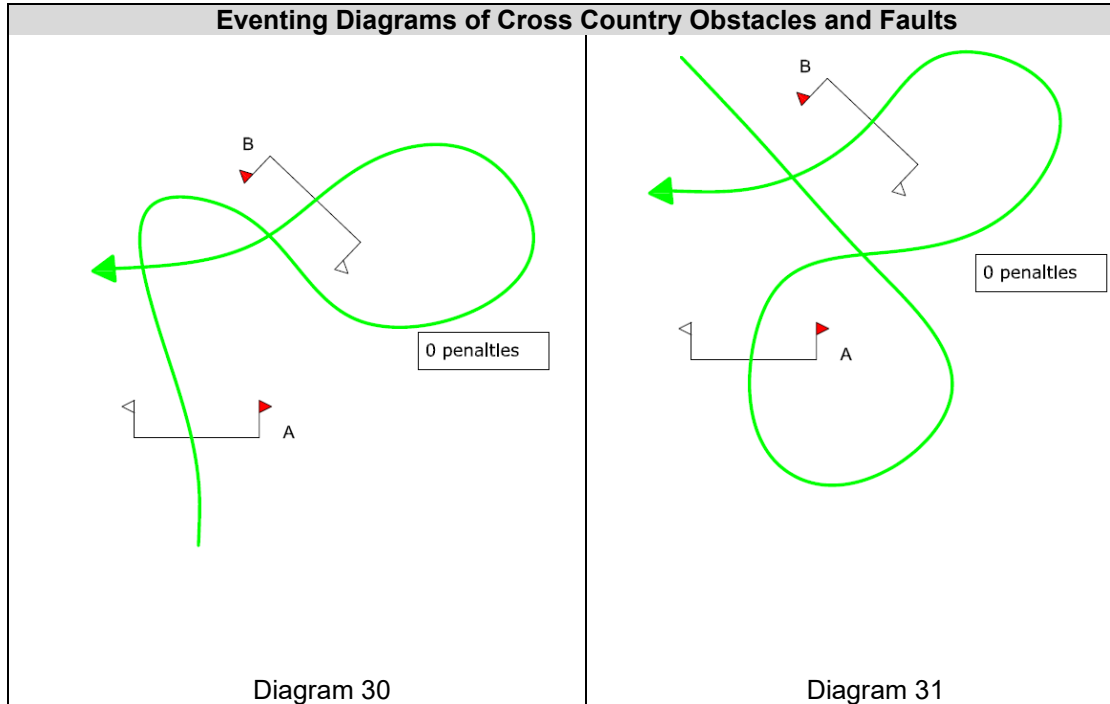

APPENDIX I: Examples of Practice Show Jumping Fences not Allowed

Examples of practice showjumping fences that are not allowed

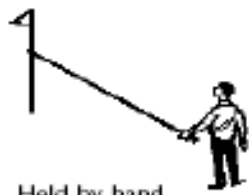

Held by hand



Neither end of cross pole supported by standard cup or fitting



Top end of sloping pole higher than horizontal pole



Pole on ground forming false ground line

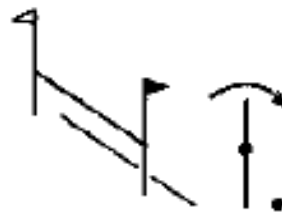

Front element higher than rear element

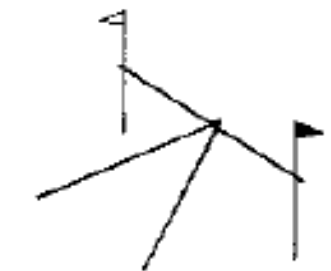
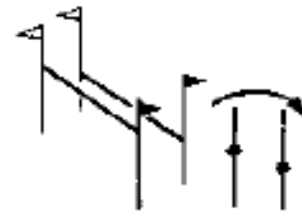

Neither end of sloping poles is supported by standard cup or fitting

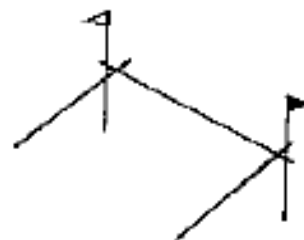

Top end of sloping poles higher than horizontal pole and not supported by standard cup or fitting in the usual manner

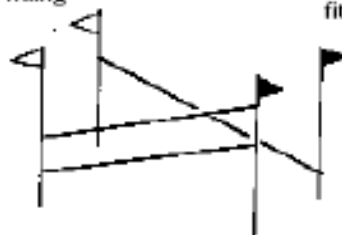

Alternate sloping poles, eg. St Andrews Cross

APPENDIX J: Prohibited Substances – Horses

Anti-Doping and Equine Controlled Medication

Horses taking part in a competition must be healthy and compete on their inherent merits. The use of a prohibited substance might influence a horse's performance or mask an underlying health problem and could falsely affect the outcome of a competition.

The equine anti-doping rules of **Eventing Ireland** are the National Rules of Horse Sport Ireland, in particular, without limitation, National Rules 1.2, 10, 11, 12, 14, 15, 16, 17, 18 (see link www.horsesportireland.ie/wp-content/uploads/2014/03/HSI-General-Rules-as-amended-15th-July-2014.pdf) and the Appendix, as may be amended from time to time, and these National Rules are and shall be construed as the rules of **Eventing Ireland** and apply to and are effective and binding on all **Eventing Ireland Members** and by participating in Horse Sport at the national level, **all members** shall be deemed to have agreed to be bound by and to comply strictly with the applicable National Rules.

The list of prohibited substances has been compiled to include all categories of pharmacological action. Eventing Ireland complies Horse Sport Ireland Equine Anti-Doping and Equine Controlled Medical Rules and with the FEI Veterinary Rule on Prohibited Substances.

The list can be found at: <http://www.FEIcleansport.org>

The presence of a prohibited substance constitutes a doping violation – if the horse has a positive anti-doping violation, the published result for that horse on the day of the anti-doping test will become invalid and the horse will show as Eliminated - PDT

APPENDIX K : Prohibited Substances - Athletes

HSI and member bodies are signatories to the World Anti-Doping Agency Code.

Eventing Ireland anti-doping rules are the Irish anti-doping rules as adopted by the Irish Sports Council, as amended from time to time. The rules contained in the said Irish anti-doping rules shall have effect and be construed as rules of Eventing Ireland.

Lists of forbidden substances are regularly updated and are available from the Eventing Ireland Office and the Sport Ireland <https://www.sportireland.ie/anti-doping>

Athletes may also refer to <http://www.FEIcleansport.org>

Remember **ALL** members of **ALL** affiliates are liable to testing **IN COMPETITION**. Only those International competitors nominated by FEI are liable to testing out of competition.

Athletes are only tested at International events in Ireland. However, **from 2021 any competitor may be tested at national or local level of event.**

Prohibited substances include TRAMADOL and CODEINE, {both commonly used for pain relief, eg: Zydol, Solpadol, Solpadeine} and intra articular or joint injections of steroids. Caffeine and Nicotine levels will also be monitored. However Athletes are patients too and prohibited substances may be used if a TUE (**Therapeutic Use Exemption**) is granted.

If you are taking therapeutic medication, inhalers or long term prescribed medication, you must submit a Therapeutic Use Exemption Form (TUE Form) to the Sport Ireland. Failure to do so could result in you being banned from competition.

Please note many prescriptions, over the counter medicines and supplements contain prohibited substances.

What is a Therapeutic Use Exemption (TUE)? Athletes may have illnesses or conditions that require them to take particular medications. If the medication(s) an Athlete is required to take to treat an illness or condition, happens to fall under the WADA Prohibited List, a Therapeutic Use Exemption (TUE) may give that Athlete the authorisation to take the required medication(s). National and International Level Athletes need to complete a Therapeutic Use Exemption Form for any substances they take or methods they use which are on the World Anti-Doping Agency (WADA) Prohibited List. Please note: An Athlete must apply for a TUE no less than 21 days prior to his or her participation in any sports event. **Warning:** Strict liability means that an Athlete is responsible for any prohibited substance found in his/her system. The presence of a prohibited substance constitutes a doping violation.

If requested by an official appointed for the purpose, an Athlete must supply the required samples of body fluids for analysis. **Failure to do so will be taken as if a positive result had been obtained.**

Any Athlete guilty of a doping violation will be reported to the Disciplinary Committee and will be subject to a 2 year ban from competition.

If in doubt regarding any medication or supplement, please email Dr Mary Flannery or contact:

Sport Ireland
The Courtyard
Sport Ireland Campus
Snugborough Road
Blanchestown
Dublin 15
D15 PN0N

Tel: 00 353 1 8608800

contactus@sportireland.ie

APPENDIX L: Code of Ethics & Good Practice for Children's Sport in Ireland

Eventing Ireland has adopted *Horse Sport Ireland's Code of Ethics and Good Practice for Youths and Vulnerable Adults in our Sport* ("HSI Code of Ethics"), as may be amended from time to time, and the HSI Code of Ethics shall have effect and be binding upon all persons required to be vetted under the National Vetting Bureau Act 2012 and all persons referred to in the HSI Code of Ethics, and all such persons shall be deemed to have agreed to be bound by and to comply strictly with the HSI Code of Ethics."

The Code of Ethics and Good Practice for Children's Sport in Ireland is for the benefit of everyone involved in children's sport - children, parents/guardians and Sports Leaders, etc. By following the principles, policy and practice guidelines contained in the Code, adult sport leaders are playing their part in providing an enjoyable and safe environment in which children can learn and thrive.

As citizens, adults have a responsibility to protect children from harm and to abide by government guidelines in responding to and reporting child protection concerns. This responsibility exists wherever such concerns might arise, whether inside or outside sport. Guidelines contained in the Code of Ethics and Good Practice for Children's Sport in Ireland took account of the UN Convention on the Rights of the Child and is in accordance with government guidelines in the documents *Children First: National Guidelines for the Protection and Welfare of Children (IRL)* and *Our Duty to Care (NI)*. The guidelines contained in the Code are complimentary to, and do not substitute, the government guidelines, which should be available within sports clubs/organisations.

The Code of Ethics and Good Practice for Children's Sport is built upon a number of core principles relating to the importance of childhood, the needs of the child, integrity and fair play, and relationships and safety in children's sport. It addresses issues relating to the roles and responsibilities of all involved in children's sport, and underpins the importance of policies and procedures in providing quality leadership for children in sport. It outlines principles of good practice and child protection policy and procedures.

The full application of the Code of Ethics and Good Practice for Children's Sport by everyone in sport will help to ensure the promotion of happy, healthy and successful experiences for children and their Sports Leaders.

The rules of Eventing Ireland regarding children in sport in Ireland are the Sport Irelands "Code of Ethics and Good Practice for Children' sport in Ireland" as indicated above and shall be construed as rules of Eventing Ireland.

For more information, please see: <https://www.horsesportireland.ie/governance/child-welfare-safeguarding/>

NOTE: *Eventing Ireland requires all officials communicating with a minor to have an adult third party present, ie: parent/guardian.*

Eventing Ireland Child Safeguarding officials are:

Child Welfare Officer	Debbie Byrne
Designated Liaison Person	Julia Watson
Designated Liaison Person	Vanda Stewart

APPENDIX M : Approved Hat Safety Standards

The Quality Testing labels include, but are not limited to the following:

BRITISH & EUROPEAN

AMERICAN

AUSTRALIA & NEW ZEALAND











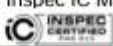

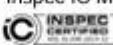
Please also refer to Rule 11.2 Protective Headgear

PLEASE NOTE THAT FROM 1 JANUARY 2026, THE FOLLOWING HAT STANDARDS WILL NO LONGER BE ACCEPTED, DUE TO THE AGE OF THE HATS MADE TO THESE STANDARDS:

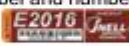
- PAS 015 1998
- SNELL 2001

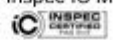

Hats must meet All of the requirements in ONE of the following rows:

	Standard and Date	Quality Assurance Mark	Examples
1	PAS 015 (2011)	AND MUST HAVE BSI Kitemark  Or Inspec IC Mark 	
2	VG1 01.040 (2014-12)	AND MUST HAVE BSI Kitemark  Or Inspec IC Mark 	
3	ASTM F1163 (2004a or 04a onwards)	AND MUST HAVE SEI mark 	
4	SNELL E2016	AND MUST HAVE Official SNELL label and number 	
5	AS/NZS 3838 (2006 onwards)	AND MUST HAVE SAI Global mark 	
6	EN1384: 2023	AND MUST HAVE BSI Kitemark  Or Inspec IC Mark 	

IMPORTANT INFO FOR CROSS-COUNTRY ACTIVITIES: Only a "Jockey Skull" of an even round or elliptical shape with a smooth or slightly abrasive surface, having no peak or peak type extensions should be worn for any XC activity. Noticeable protuberances above the eyes or to the front, not greater than 5mm, smooth and rounded in nature are permitted. A removable hat cover with a light flexible peak may be used.

HEAD CAMS: When hats are tested against the requirements of a standard, they are done so with no extra additions on the hat i.e. with no head cam attached. Therefore, it is currently not known how the addition of a protuberance such as a head cam, affects how the hat would respond during an impact. Therefore, the use of HEAD CAMS are not recommended at any BHS activity. This includes use on the head, chest, bridle or any other part of the horse or rider.

APPENDIX N: Eventing Ireland Stewards 2026

Level	Region	Name
Senior Steward / Technical Advisor		
EI120	MR	Mr Pat Coleman
EI120	NLR	Ms Linda Christie
EI120	SLR	Mr Gerard Crehan
EI120	NR	Mr Denis Currie
EI120	NR	Mr Terry Johnston
EI120	SL	Mrs Gillian Kyle
EI120	SLR	Mr David Lee
EI120	SLR	Mr John Lyttle
EI120	SLR	Mrs Ger Lyttle
EI120	SLR	Ms Maria Kenny
EI120	NLR	Lt Col Brian MacSweeney
EI120	NLR	Ms Gervaise Maher
EI120	SLR	Mr Donal McKenna
EI120	NR	Mr Richard Nesbitt
EI120	NR	Mr Stuart Stirling
EI120	NR	Mrs Georgia Stubington
Stewards		
EI115	NR	Mr Ronnie Beggs
EI115	NR	Ms Jayne Foy
EI115	WR	Ms Ann Hanniffy
EI115	NLR	Mrs Elaine Lait
EI115	NR	Mr David Lowry
EI115	MR	Mr Alasdair MacDonald
EI110	NLR	Ms Christine Brooks
EI110	NR	Mrs Vina Buller
EI110	NR	Mrs Heather Champion
EI110	MR	Mrs Bets Coleman
EI110	NR	Mr Lithgow Currie
EI110	NR	Mrs Barbara Dixon
EI110	MR	Mrs Sarah MacDonald
EI110	NR	Mrs Nicola Manningham-Buller
<i>EI110 Mentored</i>	NR	Mr Corey Mawhinney

Assistant Stewards (Up to EI110)

NR	Ms Elaine Douglas
MR	Ms Elaine Galvin
SL	Mr Dereck Hamilton
SL	Mr Jerome Kennedy
NR	Mr John McBride

NR	Mr Philip McLean
NR	Ms Vanda Stewart
WR	Mrs Trish Warren
NR	Ms Vickie White

Please note that this list is subject to additions/deletions/alterations at any time

APPENDIX O: Eventing Ireland Accredited Course Designers 2026

Grade	Name	Design Up To
List A	Paul Brady	FEI Level 3
List A	Peter Fell	FEI Level 3
List A	Andrew Fell	FEI Level 3
List B	Dereck Hamilton	FEI Level 2
List B	Adam Stevenson	FEI Level 2
List B	Ray Doyle	FEI Level 1
ACCREDITED COURSE DESIGNERS		
List A	Danny Duloherly	EI120
List A	Eugene O'Neill	EI120
List A	Clive Corrigan	EI120
List B	Vina Buller	EI115
List B	Tony Ennis	EI115 Mentored
List B	Dominic Furnell	EI115 Mentored
List C/B	Andrew Napier	EI115 Mentored
List B	David O'Meara	EI115
List B	Rodney O'Donnell	EI115
List C	Sally Corscadden	EI110
List C	Gerald Furnell	EI110
List C	Chris Ryan	EI110
List C	Jonathan Hagan	EI110
List C	Will Kearney	EI110
List C	David O'Connor	EI110
CONDITIONAL COURSE DESIGNERS		
List D	Noel Fitzpatrick	EI100

All Conditional Course Designers must be mentored by a List A Course Designer until they have been assessed and accredited as per the Course Designer Guidelines/Log Book (available to download via the EI Website <https://www.eventingireland.com/app/uploads/2026/02/course-design-manual-and-guidelines-2024.pdf>)

Restricted course designers are only approved to build at one venue (usually their own).

Please note that this list is subject to additions/deletions/alterations at any time. Please contact Head Office if you have any questions.

APPENDIX P: Training Classes: Arena Eventing & Combined Training Rules

Arena Eventing and Combined Training Competitions (Training Classes) are a concept intended to give non-members a taste of Eventing with the aim of encouraging them to become full members of Eventing Ireland. They are also an opportunity for members to give young or unregistered horses an outing without the pressures of being in a full competition and to promote Training in general.

An Athlete must be in the year of their 12th birthday to compete.

A Pony must be 5 years old or over and a Horse must be 4 years old or over, with a minimum height of 138cm.

Training competitions are covered by the Eventing Ireland Insurance Policy, but only if the competitions comply with these Rules in Appendix P and the Eventing Ireland Rules.

The format of Training Competitions may vary from venue to venue depending on the competition facilities available.

TRAINING CLASS TYPES

Class	Format	Dressage** Tests	Show jumping Max 10 SJ fences	Cross country Max 20 XC Fences Max Distance 2000m
EI80 (T)	3 Phase	BE90 standard	80cm max	80cm max
EI90 (T)	3 Phase	BE90 standard	90cm max	90cm max
EI100 (T)	3 Phase	BE100 standard	100cm max	100cm max
TE 80	2 Phase		80cm max	80cm max
TE 90	2 Phase		90cm max	90cm max
TE 100	2 Phase		100cm max	100cm max
TE 105	2 Phase		105cm max	105cm max
TE 110	2 Phase		110cm max	110cm max
CT 80	Combined Training	BE90 standard	80cm max	
CT 90	Combined Training	BE90 standard	90cm max	
CT 100	Combined Training	BE100 standard	100cm max	
CT 105	Combined Training	BE110 standard	105cm max	
CT 110	Combined Training	BE110 standard	110cm max	
CT 115	Combined Training	BE115 standard	115cm max	
CT 120	Combined Training	BE120 standard	120cm max	
AE 80	Arena Eventing	BE90 standard	80cm max (incl. knockables*)	
AE 90	Arena Eventing	BE90 standard	90cm max (incl. knockables*)	
AE 100	Arena Eventing	BE100 standard	100cm max (incl. knockables*)	
AE 110	Arena Eventing	BE110 standard	110cm max (incl. knockables*)	
AE 115	Arena Eventing	BE115 standard	115cm max (incl. knockables*)	
AE 120	Arena Eventing	BE120 standard	120cm max (incl. knockables*)	

All Training dates must be submitted to the Dates Committee for approval. Training cannot run in the same region on the same date as an affiliated national event. In addition:

- It is recommended that Training days should run during the week where possible and may not run within 6 days of a **National event in the same Region.**
- Training Classes with all three phases can only run at an affiliated National event (ie: EI80 (T), EI90 (T), EI100 (T)).
- Falls and eliminations in EI100(T), EI90(T) and EI80(T) classes are monitored and will be reviewed as part of ongoing safety measures.
- Training Classes are NOT Schooling classes and Eventing Ireland rules must be obeyed at all times.

*** All portable cross country fences must be securely fixed, as per the Eventing Ireland Course Designer Guidelines– found on the EI website [HERE](#).**

**** Organiser may also use alternative dressage tests (ie. FEI Test) for Arena Eventing or Combined Training, however, they must be approved in advance by Eventing Ireland**

SHOW JUMPING AND CROSS COUNTRY PHASES

- The Show Jumping track is to be no more than **10 Fences** for each class
- The Cross Country course should be no more than **20 Fences** (including combinations) for each class and the track should be no longer than 2000m for all classes.
- The show jumping can be immediately followed by cross country jumping without a break
- For Arena Eventing, the cross country phase may be run on sand – **however, the fences must be correctly secured, as per the Eventing Ireland Course Designer Guidelines.**

SAFETY

There will be an emphasis on **safety** at the competition which will run under the competition rules of Eventing Ireland.

- To comply with insurance, approved protective headgear and safety attire must be worn in accordance with EI rules.
- At a minimum, one **Qualified First Aider** must be in attendance for all training (Please refer to Appendix Q)
- If an Athlete is eliminated in show jumping in accordance with EI rules, they must receive permission from the EI Steward, on the day, to compete cross-country, the exception being if the show jumping and cross country phases are run together, then the Athlete will automatically be eliminated.
- At any time the EI Steward may at his/her absolute discretion eliminate an Athlete for safety or other reasons as per the current Eventing Ireland Rule Book.
- All approved Training Events are covered by Eventing Ireland insurance and any **injuries sustained MUST** be reported to Head Office as soon as possible using the forms (which can be downloaded from the website)
- All falls in Training classes held at national events will be recorded on the national Fall Report
- Risk Assessment forms for the training event must be sent to Head Office at least three days before the running of the event
- If there are no medical facilities/area on site, there should be an area set aside to treat any casualties (eg: a trailer with a chair, blankets if necessary)

EI STEWARD AND OFFICIALS

- An EI Steward is required at **Arena Eventing** which includes a cross-country phase, and must be in attendance **for the duration of the competition.**
- An EI Steward will be appointed by Eventing Ireland, from the EI list of Stewards or Assistant Stewards (As per Appendix I).
- The Course Designer must supply the Eventing Ireland Head Office and the EI Steward, with a list of fences for each track, the distances and the heights/description of each fence, for each class, **in advance of the competition**
- The Eventing Ireland Steward must sign off the work of the Course Designer on their site visit prior to the running of the event. If the Steward believes there should be changes to be made from a safety point of view, these must be done and signed off prior to the event taking place
- The EI Steward will approve show jumping and cross country tracks before start of competition **with an emphasis on safety.**
- The EI Steward **must** submit standard reports of any serious incidents to Head Office.
- It is the responsibility of the Organiser to arrange Dressage Judges, SJ Officials and XC fence judges and this can be done with the help of your region.

ADMINISTRATION

- Competitors Numbers and Fence Judging books may be supplied by the venue when required. These can also be purchased, at cost, from EI Head Office. Alternatively, the competitors can print numbers off themselves at the request of the Organiser.
- Dressage times are the responsibility of the Event Organiser
- Head Office will publish the times on the website if they are provided in a suitable, publishable format (ie: word or excel)

JUDGING/SCORING FOR TRAINING COMPETITIONS

- Each phase will be judged and scored as per the EI Rules for that phase.
- In 2 phase competitions, the show jumping and cross-country may be run without a break between phases.
- Results must be sent to Head Office within two days of the competition in an excel or word document so they can be published online.
- Results will NOT be permanently recorded – they will be published for up to five days after the competition.
- If the Organiser sends Head Office publicity photographs from these events, they will be published and will be removed after one week.

PRIZES

- Prizes (either money or prizes in kind) will be at the discretion of the Organiser.
- If prizes are sponsored, the sponsor may wish to attend the event and have a formal prize giving

ENTRIES

- Entry fees may not be higher than €50/£50 for any Training Class **except where the classes are (T) classes and normal entry fees apply.**
- Unless otherwise agreed with the organiser, entries for any Training Class must use the EI entry system.
- Either a fee of €100/£100 or €5/£5 per entry (whichever is the lesser or agreed in advance by Eventing Ireland) will apply and each entry will be subject to an administration charge of €3/£2
- The Event Organiser has the right to cancel on the Tuesday at close of entries if the entries make the event not viable.
- **Please note once the event is affiliated to Eventing Ireland, entries must be taken online via the Eventing Ireland website as noted above.**

APPENDIX Q: Medical Cover at Events

Medical Cover at Events						
Activity	Type	Organiser	Qualified First Aider	Fully Equipped First Aid Kit	Paramedic NI or Doctor	Ambulance
Dressage	Training	Yes	Yes	Yes		
Show Jumping	Training	Yes	Yes	Yes		
Cross Country	Training	Yes	Yes	Yes	Yes**	
National Competition *		Yes			Yes	Yes x 2

* This refers to national competition where Rule 18, Medical applies. For Training events, Appendix P applies. The organiser of the event must be on site at all times

** Either a Doctor, Paramedic or EMT or higher would be suitable for training and they must come equipped with sufficient medical supplies in case of an emergency

Definitions of Medical Cover:

Organiser: The person who will co-ordinate medical requirement in compliance with minimum standards, including communication to Head Office in the event of a serious accident. This may be a Qualified first aider

Qualified First Aider: A person who holds a First Aid at Work certificate. First Aid at Work certificates must be revalidated after no more than 3 years

Fully Equipped First Aid Kit: All venues must have a fully equipped first aid kit designed for a workplace (as per www.hse.ie) – not one for the home or personal use

Paramedic/Paramedic: A practitioner who has completed PHECC's guidelines – qualified to provide care and transport of a patient with serious or life threatening injuries

APPENDIX R: Dates Committee - DC

The Dates Committee (DC) has the authority of the Board to decide all applications for dates and upgrades in accordance with these rules.

The objective is to annually produce a balanced Calendar that maximises Members' opportunities to compete at all levels whilst maintaining Event viability

It is the wish of the DC and the Board that agreement on dates by the parties directly involved should be the preferred method of operation and applicants are encouraged to discuss dates with each other.

For clarification purposes, a new venue, or venue which has not run a national EI event for 5 years or longer may only run up to EI110 classes during its first year, unless approval is granted by the Board to run up to EI 115.

The Board requests a maximum of two national events should run each weekend of the season (March – October). Only under exceptional circumstances and with approval by the Board and event organisers concerned, additional events may run.

Unless otherwise agreed by the DC, venues may only apply for two dates at the time of the Dates Committee Meeting. If there are still vacancies on the calendar, the third date from a venue may be considered or will be 'floating' until such a time a suitable date is available in the region (see **Floating Dates** below).

Where two national events plan to run on the same weekend, and to alleviate any potential objections between event organisers, the geographic spread of events will be considered to ensure members opportunities to compete are not restricted and that the event remains viable. Exceptions may be made with the agreement of the Dates Committee.

International dates do not affect dates for national eventing. International venues are encouraged to run national events during the year and must apply for national dates as detailed herein.

It is the desire of the Board that all dates should be decided by the agreement of all those intending to run on a date or weekend and are present or represented at the annual Dates Meeting. If the agreement of all cannot be obtained in this way, the DC will have the final decision.

The DC may do its business, with the exception of its Annual meeting, by email and may vote by email. Voting arrangements are as per Board; Chairman of Dates Committee having a casting vote.

Operational arrangements for National Date Applications

In early Autumn each year, applications for national dates for the following year will be sent by email to all venues and are to be returned by the stated deadline to Head Office. The completed applications will be summarised and circulated to all members of the DC to consider and prepare a draft schedule for the coming year. Late applications may not get their requested dates.

In reviewing the dates, the DC will take into consideration the following:

- geographic spread and frequency of events throughout the regions
- whether events can run at beginning and end of the season (to avoid unnecessary cancellations)
- the scheduling of events with higher classes to facilitate Athletes/owners seeking to earn FEI qualifications.

Maximum Entries

The total number of entries for a national event running on one day is **recommended to be** 300-320 (with Board approval), so long as the phases can be run independently. It is the event organisers responsibility to advise maximum entries to Head Office on its dates application form.

Event Organisers must consider the number of entries and limited daylight hours when applying for dates at the beginning and end of the season

Annual Dates Meeting

The Annual Dates Meeting will be held each Autumn. All Organisers, Landowners and Regional Chairmen to be advised and invited by email to attend this meeting. Those unable to attend should send a representative.

The Schedule of Dates for the coming year will be agreed at that meeting and submitted to the EI Board for consideration and approval not later than its November Board Meeting, or by email as soon as the Event Dates Schedule is ready.

Only approved dates will be published on the Eventing Ireland website.

Event Organisers will be requested to send in a more detailed event form stating dressage tests, classes, stabling information etc as soon as possible in the New Year and not later than 8 weeks prior to the opening of entries to their agreed date.

National Championships

The National Championships is run for the Eventing Ireland membership and will be the only event run during its agreed weekend.

Upgrading to a Higher Class

A national venue must give a minimum of one month's advance notice to the Board of its intention to upgrade to a higher class than that for which it has been approved. It must have successfully run events for the previous two years, to the maximum distances as per these rules and all Fence Dimension sheets must have been lodged with Head Office. The Course Designer must be accredited in accordance Course Designer Log Book or be mentored by a qualified Course Designer. Stewards Reports will also be reviewed when considering an events request to upgrade.

Class upgrades during the season may only be made if the venue meets the criteria set out in the Course Designer Guidelines and is approved by an appointed Technical Advisor.

The Board will appoint an appropriate grade Technical Advisor or Steward to examine the venue and discuss the proposals for upgrade and to report back to the DC and Board. If approval is granted by the Board, the region must monitor progress with the TA/Steward.

Cancellation of a National Event (See EI Rule 3.9)

If an event is unable to run its agreed date due to circumstances outside of their control (ie: weather), Head Office must be notified in writing **as soon as possible**. An event can only be cancelled in writing by either the Event Organiser or the appointed Steward.

The cancelled date will then be advertised to event organisers as a Vacant Date.

Vacant Dates

If a date becomes vacant, the date will be advertised to all organisers/landowners and regional chairmen. Applications will be considered in the following order:

1. To a suitable venue able to run classes not higher than that of the vacating venue, in the region where the vacancy occurred
2. To a venue outside the region which will be of the same standard as the cancelled fixture.
3. 'Floating Venue' will be approached at the discretion of the Dates Committee.

The decision of the DC will be final.

Floating Venue

A Floating Venue is a venue who was not able to have its original date application finalised at the Annual Dates Committee Meeting or has cancelled an event but is unable to find a suitable vacancy on the calendar at the time of its cancellation but has specifically requested a month when it could be suitable to run. A Floating venue, if suitable, will be given first choice if a vacant date becomes available in their region.

Rescheduled Dates

Events which have cancelled may apply to the DC for a new date within one month of their cancellation if there is a suitable, available date on the calendar. Events already running on this proposed weekend will be consulted by their regional DC representative. The DC Committee decision will be final.

Addition of Classes

If an event wishes to run additional classes to those agreed at the Dates Committee Meeting and are published on the website, Head Office must be notified in writing at least one week prior to the event date to give competitors a chance to plan their diary. This does not apply for additional classes at a particular level or specific sponsored classes. The Eventing Ireland Steward must also be notified of this change by the Event Organiser.

HSI High Performance Classes at National Events

It is the responsibility of the HSI High Performance Manager/Director to liaise and obtain agreement directly with the event where they wish to have special class/test. The HSI HP Manager must advise Head Office in writing at least 3 weeks prior to the event so appropriate tests can be published.

Dates Committee Decision Policy

If the Dates Committee does not have a unanimous decision, the majority vote will prevail
If there is equality in votes the Chairman will make the casting vote

An application by a venue for a date does not mean it will be accepted by the Dates Committee or Eventing Ireland Board. The National Dates Committee and Eventing Ireland Board has the right to refuse or retract a date on the calendar without prejudice, at any time.

Operational arrangements for Home International Date Applications

All International dates and class applications are approved by the Board and then submitted to HSI.

International classes cannot be changed without the agreement of the EI Board who will advise changes to HSI. Any request to change international classes must be sent in the first instance to [Alison Packman](#) in writing. Only in exceptional circumstances, ie: by request from HSI or the FEI, can dates or international classes be amended.

Unless otherwise agreed by the venues concerned, and with agreement from the EI Board, there must be a minimum of 3 weeks from the first day of dressage for CCI-S only events and 4 weeks for CCI-L events

National classes run at Home International Events are run under the rules of Eventing Ireland. Any national competition run at a venue where FEI Rules apply are also subject to those rules, particularly disciplinary rules.

National events may run on the same dates as Home International events.

Timeline for International Date Applications

JUNE	Head Office will invite all event organisers to submit their outline date applications for Home International events to be run in the following year. Deadline: 30 June.
JULY	All applications will be considered by the DC DC will present its recommendations at the July/August Board meeting (whichever is sooner). The Board decision on Home International Dates will be submitted as recommendations to National Federation (HSI). HSI will address any queries to the Board.
AUGUST	HSI communicates directly with applicants.
SEPTEMBER	HSI submits its recommendations to FEI
OCTOBER	FEI make the final decision which is usually announced in October. It would be unusual for an application that has been supported by both EI and HSI to be refused.

Multiple Applications for an International Date

Should two or more applications be submitted for the same international date, the EI Board will consider the following:

- Have one or more of the applicants ever run on the requested date previously?
- Have applicants been notified that there are multiple requests for this date and can an amicable resolution be reached?
- Have the applicants run international events before?
- Have the applicants ever cancelled when running on that date, ie: due to weather, financial reasons, other (excluding Covid)?
 - If they have cancelled, how much notice was given to Eventing Ireland to find another venue?
 - Was another venue found in time?
- Has the EI Board met with the applicants to discuss the situation?
- Have all requested documentation been supplied if requested (ie: insurance, financial plan, marketing/sponsorship)
- Have the TD's reports been sought/considered by the Board when making a decision regarding the date?

The EI Board's decision regarding allocation of dates will be final

Event Code of Conduct

Both International and National events must observe the EI Code of Conduct and FEI Code of Ethics. Any event, either International or National, who is in breach of the either may, by instruction of the EI Board, have their date withdrawn from the calendar.

HSI will be notified if an International event is in breach of either the Event Agreement or Code of Conduct and will advise the FEI to remove said venue/date from the FEI calendar. International events will forfeit any agreed funding and support from Eventing Ireland.

Members of the Dates Committee:

All members elected annually by the EI Board at its meeting after the AGM.

DC Chairman:	Niki Potterton
General Manager:	Alison Packman
Committee:	Denis Currie
Committee:	Michael Ryan

The Chairman of the EI Board is ex-officio of the Dates Committee but has no voting rights.
Only date applications approved by the DC and EI Board will be published on the Eventing Ireland calendar.

APPENDIX S: Important Contact Information
CONTACT INFORMATION

Head Office		
Alison Packman	alison@eventingireland.com	General Manager
Tricia Clark	headoffice@eventingireland.com	Head Office Administrator
Please contact Tricia for all enquiries in the first instance.		
Chloe Hester (Part Time)	info@eventingireland.com	Administrator and Accounts
Pat O'Connor (Part Time)	pat@eventingireland.com	Event payments
Dora Beacom (NR)	dorabeacom@live.co.uk	NR Queries

Eventing Ireland Regional Contacts		
Region	Chairman	Secretary
Northern	Georgia Stubington sweetwallevoting@gmail.com	Dora Beacom dorabeacom@live.co.uk
North Leinster	Gervaise Maher gervaisemaher22@gmail.com	
South Leinster	Bridget McGing bridgetmcging@gmail.com	Orla O'Neill orlaoneill@gmail.com
Munster	Melanie Purcell eimunster@mail.com	Ruth Wardell eimunster@mail.com
Western	Ralph Conroy Ogenhal@yahoo.com	Marie Dunne rmdunne@hotmail.com

Eventing Ireland National Underage Regional Co-Ordinators		
Region	Pony	Junior
Northern	Joanne Jarden 07803 018324	Debbie Byrne 07711 800686
North Leinster	Elaine Lait 087 2908188	Elaine Lait 087 2908188
South Leinster	Michelle Nelson 087 6651222	Jane O'Flynn 087 6996234
Munster	Clare Ryan 087 2513956	Bets Coleman 022 29350
Western	Ralph Conroy 0872744945	

HSI Approved Eventing Coaches

please click this link or go to the HSI website under Coaches:

<https://www.horsesportireland.ie/coaching/accredited-coaches/>

Youth Athlete HSI High Performance Programmes

For information regarding Youth Athletes HSI High Performance programmes, please contact Aileen Cartwright at Horse Sport Ireland (acartwright@horsesportireland.ie)

APPENDIX T: FEI Code of Ethics

The FEI Code of Ethics can be found here [FEI General Regulations -Effective 1Jan2026- Clean.pdf](#)

Connolly's
RED MILLS
SINCE 1908

**FEED YOUR
DESIRE TO WIN**

DEFINE & SHINE



// I've been incorporating DEFINE & SHINE as a high-calorie top-up alongside my horses' foundational RED MILLS diet and I've been extremely impressed with the results. It played a key role in helping my horses maintain condition and muscle mass during the most demanding periods of the season, even as workloads intensified. Ahead of travel and during competition we use the Foran Equine PRE-FUEL and RE-FUEL Gels and found them game changing when trying to support performance and recovery. These products are now an integral part of my feed room and overall nutritional toolkit. //

IAN CASSELLS,
European Eventing Championships Team Silver Medalist
World Young Horse Eventing Championships Silver and Bronze Medalist



**SCAN
HERE
FOR MORE
ON THIS
PRODUCT**



**SCAN
HERE
FOR MORE
ON THIS
PRODUCT**



**SCAN
HERE
FOR MORE
ON THIS
PRODUCT**



Connolly's
RED MILLS
SINCE 1908

To find out more about our products or nutritional services,
contact our specialist thoroughbred team:

UK: Louise Jones +44 7843 349054
IRL: Nicole Groyer +353 83 477 3873
Email: info@redmills.com
Goresbridge, Co. Kilkenny, R95 EKH4, Ireland.



www.redmillshorse.com



Connolly's
RED MILLS
SINCE 1908

FORAN

CARR & DAY & MARTIN
EST. 1765

